



VEHICLE ECO1000

CONTENTS

3.1.	MAIN COMPONENTS	3 - 2
3.1.1	Power pack – Main components.....	3 - 2
3.1.2	Vehicle ECO1000 – Main components.....	3 - 9
3.2.	ELECTRIC PANELS	3 - 10
3.3.	HYDRAULIC TAPS	3 - 11
3.3.1	Power pack – Hydraulic taps.....	3 - 11
3.3.2	Vehicle ECO1000 – Hydraulic taps.....	3 - 13
3.4.	VEHICLE SOCKETS AND CONNECTORS	3 - 14
3.5.	EB1 PANEL CONTROL BOARD	3 - 16
3.5.1	Vehicle tare and lifting/lowering keyboard.....	3 - 17
3.5.2	Electronic program navigation keyboard (keyboard F_).....	3 - 19

3.1. MAIN COMPONENTS

3.1.1 Power pack – Main components

The Power Pack is equipped with a Deutz 85 kW maximum power Diesel motor, complying with the emission standard EU Stage V (US EPA Tier 4F), and with a SCR system (see the dedicated paragraph 1.13.6).



	[]	Position/Code of the component on the general system and identification plate on the vehicle.
		Component code.

Pos.	Description	
1	Diesel engine.	[110.0267_01]
1b	Diesel engine control unit.	(110.0267) ⁽¹⁾
1c	Diesel engine diagnostics connector. For further information, see the manufacturer's manual.	(110.0266) ⁽¹⁾
2	Hydraulic motor pump 75 cm ³ .	[126.0707_01]
3	Lifting/steering hydraulic pump 55 cm ³ . The pump also controls the drive of the hydraulic coupling puller (if included in the supply).	[126.0721_01]
4	Hydraulic pump 22 cm ³ → wheel motor supercharger and motor pump.	
5	Hydraulic pump 22 cm ³ → radiator oil recirculation.	
6	Hydraulic pump intake oil filter.	[065.0664_01]
7	Lifting and steering pump oil filter.	[065.0517_01]
8	Motorization system oil filter.	[065.0442_02]
9	Oil return to tank filter.	[065.0534_01]
10a	Hydraulic oil tank purge filter.	[065.0584_01]
10b	Hydraulic oil temperature and level transducer.	[477.0029_01]
11	Diesel engine air filter.	[065.0666_01]
12	Hydraulic oil radiator.	[460.0146_01]
13	Diesel engine coolant radiator.	(110.0267) ⁽¹⁾
14a	Horn.	553.0616
14b	Reverse gear beeper.	553.3900

⁽¹⁾ = components that fall within the assembly associated with the engine code.

Continued →

Continued →





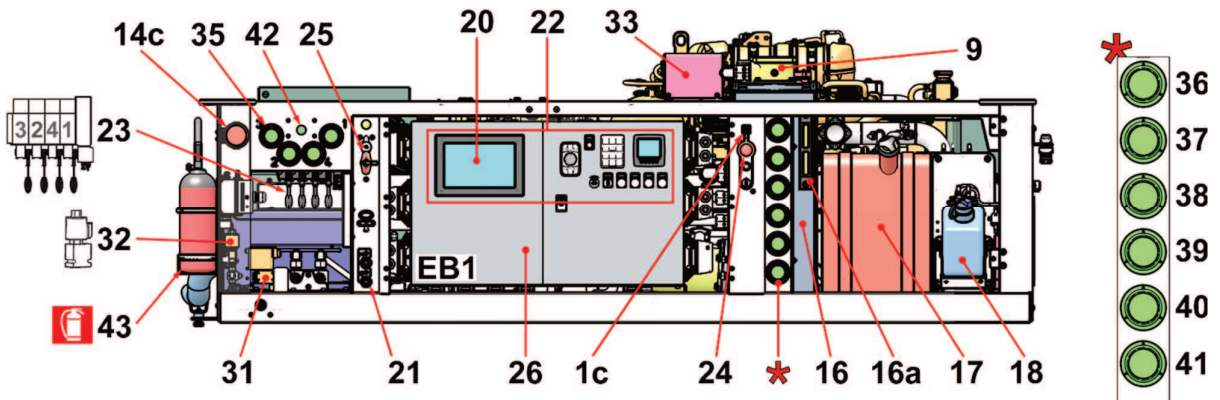
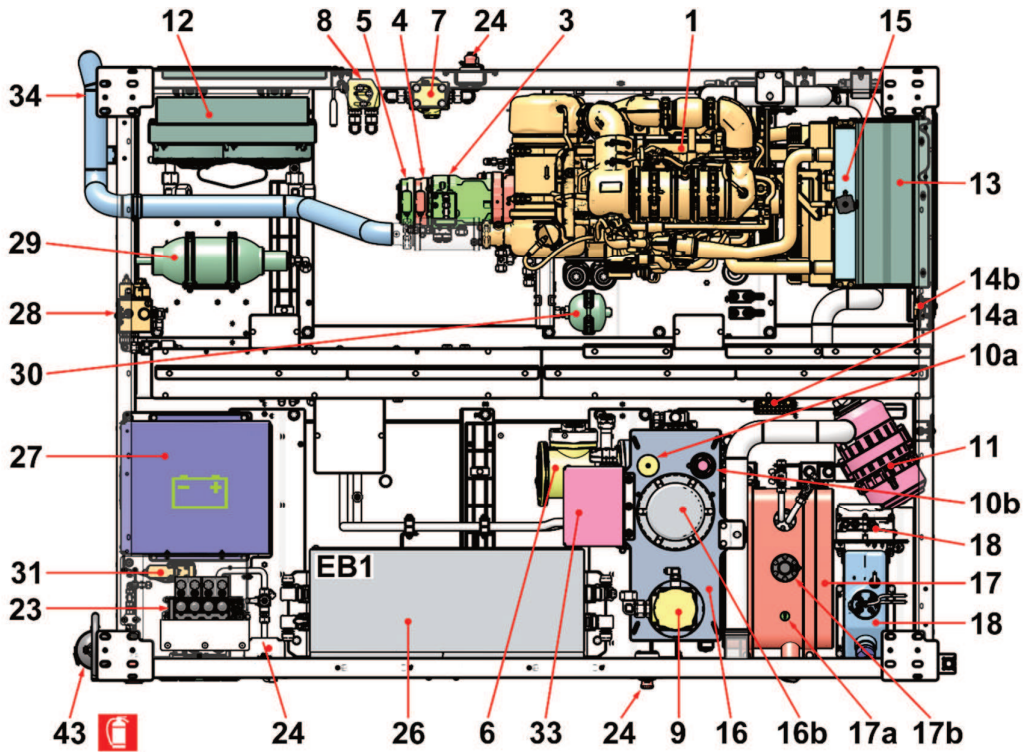
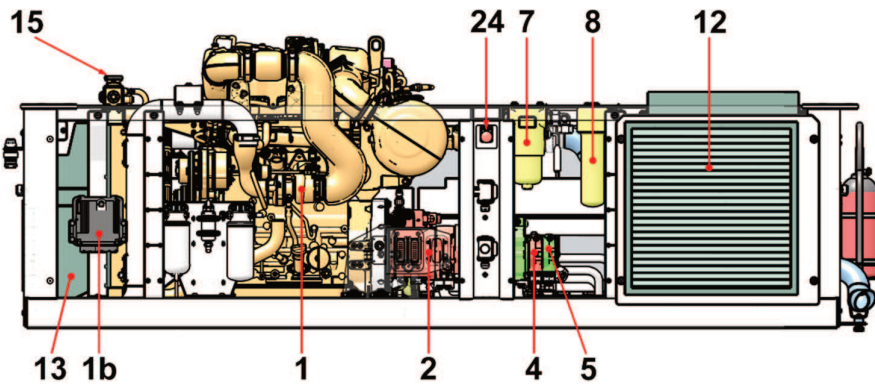



NOTE
The side views of the Power Pack are represented without the cover panels.



Continued →

Continued "Power pack – Main components" →

Pos.	Description	
14c	<p>Audible/visual warning device (buzzer).</p> <p>VEHICLE ENABLING PHASE The acoustic/light signal indicates that the system is operational; the vehicle can be started using the (I) (INIT) selector or button.</p> <div style="display: flex; justify-content: space-around; align-items: center;"> <div style="text-align: center;">  <p>(I) (INIT) selector (remote control)</p> </div> <div style="text-align: center;">  <p>(I) (INIT) button ([EB-I/K] control board)</p> </div> </div>	553.2118
	<p>VEHICLE RUNNING The acoustic/light signal indicates the presence of a serious error/fault. The type of error/fault is indicated:</p> <ul style="list-style-type: none"> • On the control panel touch screen display ([EB1]) panel → icon on home page or description on the [ACTIVE ALARMS] page. • On the radio control display, by means of the corresponding icon. 	
15	Diesel engine coolant tank.	(110.0267) ⁽¹⁾
16	Hydraulic oil tank (150-litre capacity).	156.0804
16a	Hydraulic oil in-tank level visual indicator.	[477.0015_01]
16b	Tank inspection porthole.	399.0697
17	Diesel tank (100-litre capacity).	156.0805
18	AdBlue® tank (19 litre capacity).	(110.0267) ⁽¹⁾
19	<p>AdBlue® Pump. The pump takes AdBlue® from the tank, filters it and sends it to the feeder. Inside the feeder, the compressed air and the AdBlue® additive are mixed to form an aerosol which is the injected into the exhaust of the Diesel engine.</p>	(110.0267) ⁽¹⁾
20	[EB1] control board display.	553.3583
21	<p>Hydraulic quick couplings [M] and [S]. In emergency conditions, connect an auxiliary user to the couplings in order to disengage the parking brake (see paragraph 9.5) and/or lift or lower the vehicle (see paragraph 10.8).</p>	 [090.0168_01] [090.0168_02]
22	[EB1] control board (see description in paragraph 3.5).	
23	<p>Hydraulic stability point lifting/lowering distributor block. To use the distributors, keep the enabling button (42)  pressed.</p>	[188.2078_1]
24	<p>Emergency stop. In order to be able to restart the machine, the button must be reset (pull it up).</p> <p> WARNING Use this button only in case of emergency; its operation turns off the Diesel engine and stops the vehicle very abruptly. Pressing the emergency stop button, the following residual risks can be generated:</p> <ul style="list-style-type: none"> • movement and/or overloading of the load; • possible damage to the motorization system. 	

⁽¹⁾ – components that fall within the assembly associated with the engine code.

Continued →

Continued →



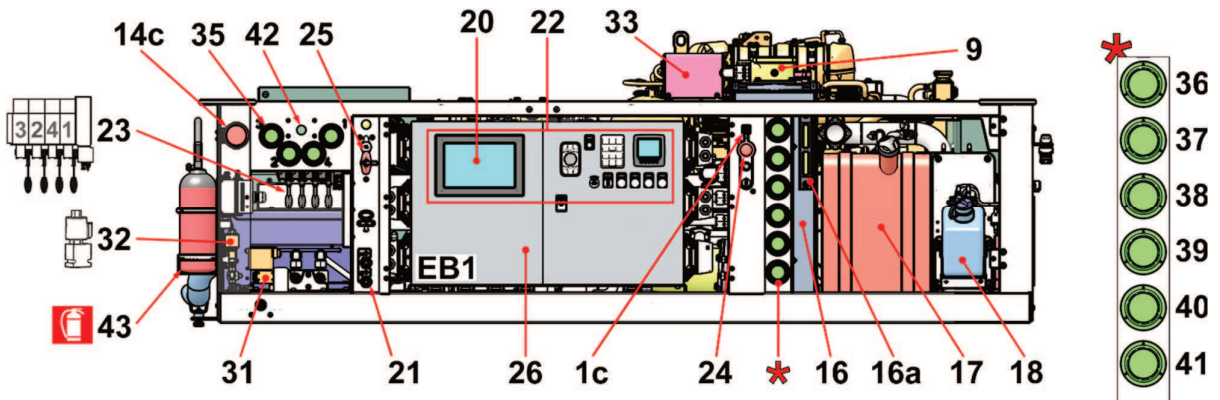
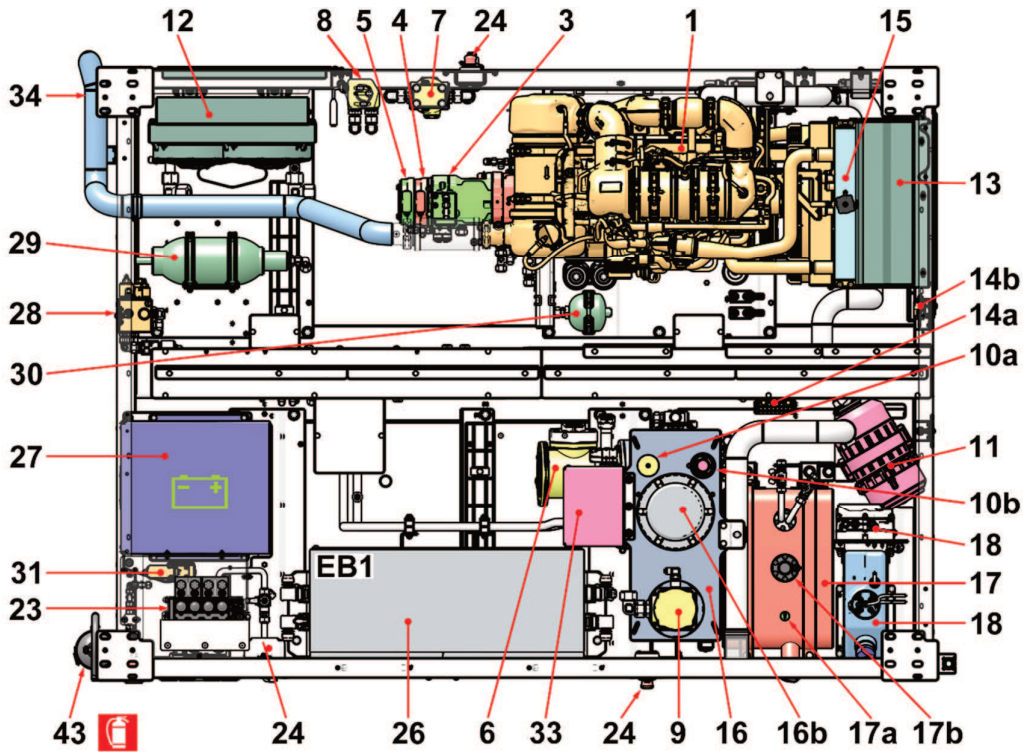
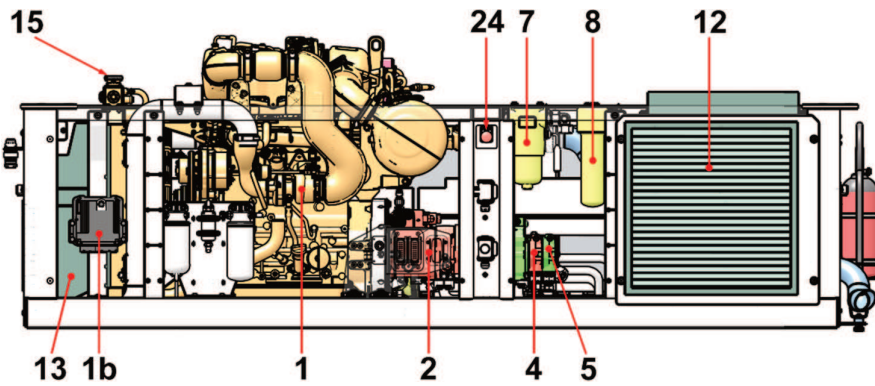

NOTE
The side views of the Power Pack are represented without the cover panels.

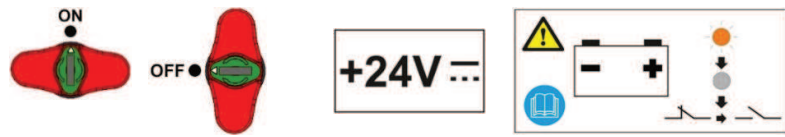

Continued →

Continued "Power pack – Main components" →

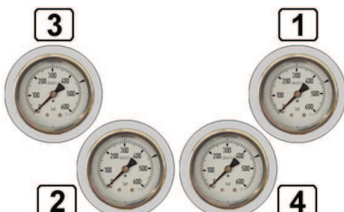
Pos.	Description
25	<p>Vehicle battery switch. To connect the batteries to the electrical system, set the handle of the [+24V] switch to [ON]. At the end of each work shift, disconnect the batteries → [+24V] Switch handle in the [OFF] position.</p>  <p>! ATTENTION <i>If the vehicle will not be in use for more than 1-2 hours, the batteries should be disconnected.</i></p> <p>! ATTENTION <i>The Diesel engine batteries can be disconnected only if the yellow light located next to the switch handle is off.</i></p> <ul style="list-style-type: none"> • Indicator light ON: <u>the batteries cannot be disconnected yet.</u> • Indicator light OFF: <u>the batteries can be disconnected.</u> 
26	[EB1] electrical cabinet. 
27	Batteries (2 x 12V in series / 155 Ah). 270.0027
28	Hydraulic braking control block. [284.0256_1]
29	Hydraulic braking control block accumulator. Loading pressure (150 bar). [002.0065_01]
30	Hydraulic motorization system accumulator. Loading pressure (10 bar). [002.0066_01]
31	Motorized axle pilot valve. [188.2004_1]
32	ELS proportional valve. [188.1884_1]
33	<p>Pressure transducer box.</p> <p>[1] – [2] – [3] – [4] → Lifting. [553.2820_01] [553.2820_02] [553.2820_03] [553.2820_04]</p> <p>[M] → Brake system. [553.2820_05]</p> <p>[AC] → Brake accumulator. [553.2820_06]</p> <p>[A] → Motorization. [553.2820_07]</p> <p>[P] → Lifting and Steering. [553.2820_08]</p> <p>[B] → Motorization. [553.2820_09]</p> <p>[V] → Motorized axle control. [553.2836_01]</p>
34	Muffler. 309.5873
35	<p>Hydraulic point pressure gauges. Hydraulic points [1] – [2] – [3] – [4].</p>  <p>[271.0080_1] [271.0080_2] [271.0080_3] [271.0080_4]</p>

Continued →

Continued →





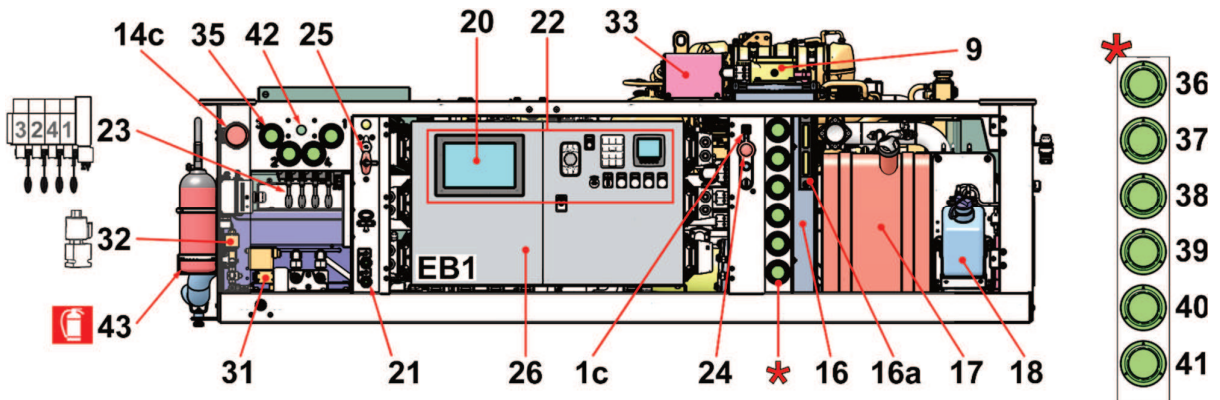
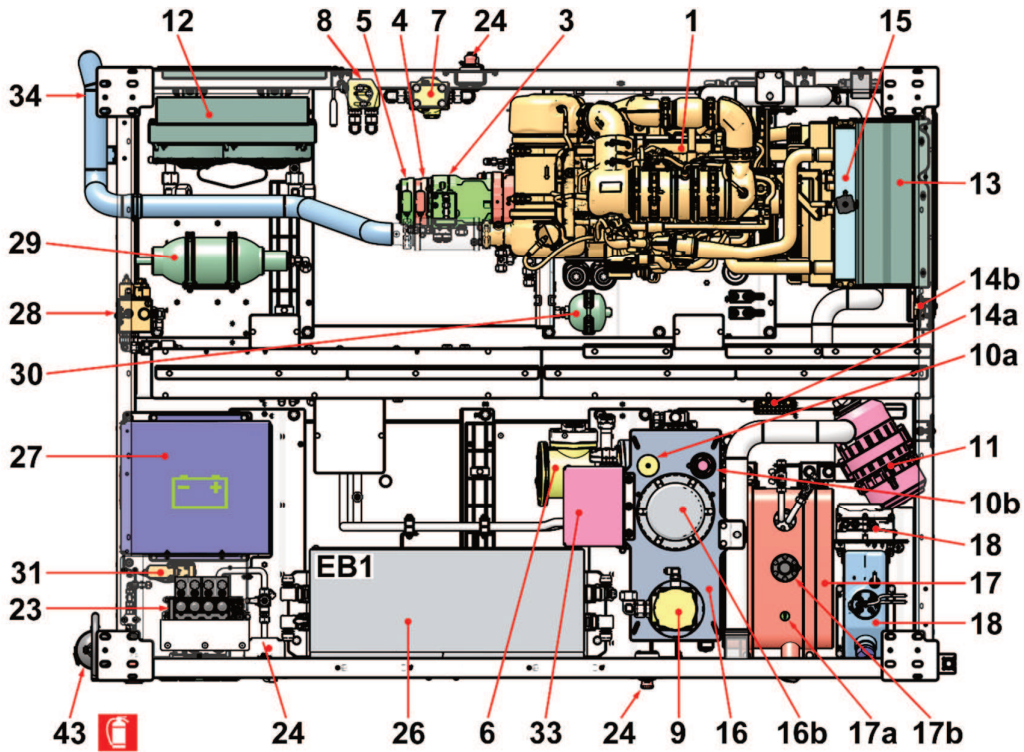
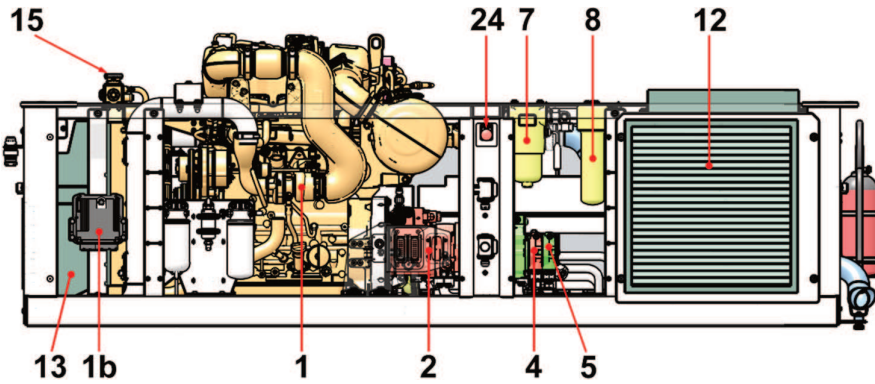







NOTE
The side views of the Power Pack are represented without the cover panels.



Continued →

Continued "Power pack – Main components" →

Pos.	Description	
36	Operating pressure gauge: the pressure range is between 30 and 420 bar.	
37	Supercharger pressure gauge: the pressure range is between 20 and 35 bar.	
38	Motorized axle control pressure gauge: the pressure range is between 0 and 25 bar. The displacement of the motorized axles occurs between 10 and 20 bar.	
39	Steering and lifting pressure gauge: the pressure range is between 15 and 380 bar. <ul style="list-style-type: none"> 15 bar: initial pressure after start-up (first 5 seconds). From 50 to 200 bar: normal stand-by pressure for steering and lifting/lowering operations. From 200 to 380 bar: ongoing intervention of the steering and lifting correction systems (for example: forcing the steering as an obstacle makes the rotation of the suspension difficult). 	
40	Brake oil pressure gauge: the pressure range is between 0 and 250 bar: <ul style="list-style-type: none"> Between 0 and 160 bar, the brake is inserted. Between 160 and 250 bar, the brake is disengaged. 	
41	Braking system accumulator pressure gauge: the pressure range is between 0 and 250 bar.	
42	Lifting and lowering commands enabling button  By holding it pressed, the button lights up and the lifting and lowering commands through the hydraulic distributor block (23) are enabled. See the relevant instructions at chapter 10.	
43	3 kg powder extinguisher suitable for type 21A 144B C fires.   NOTE Read the instructions carefully on the extinguisher and check refills within the planned intervals.	

3.1.2 Vehicle ECO1000 – Main components

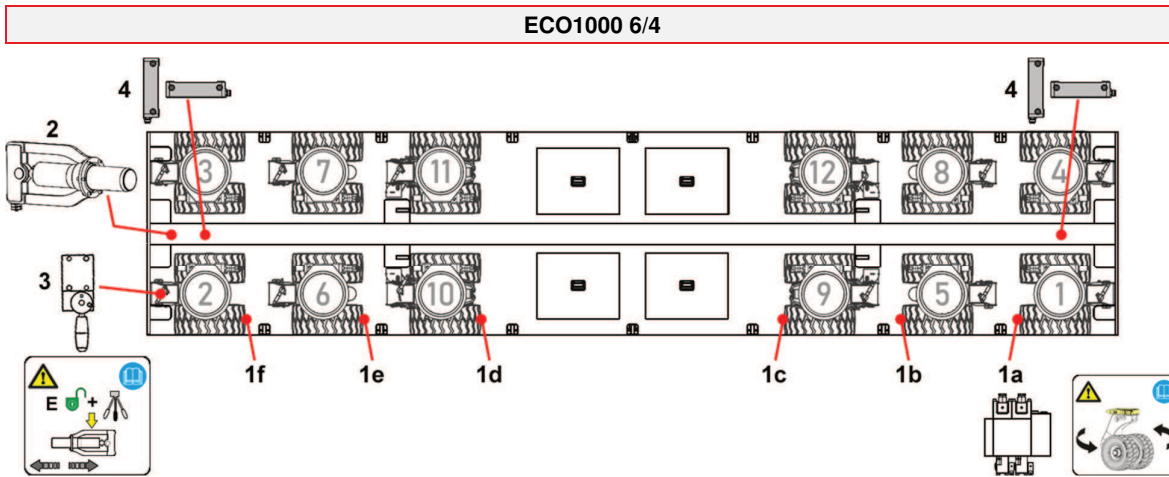





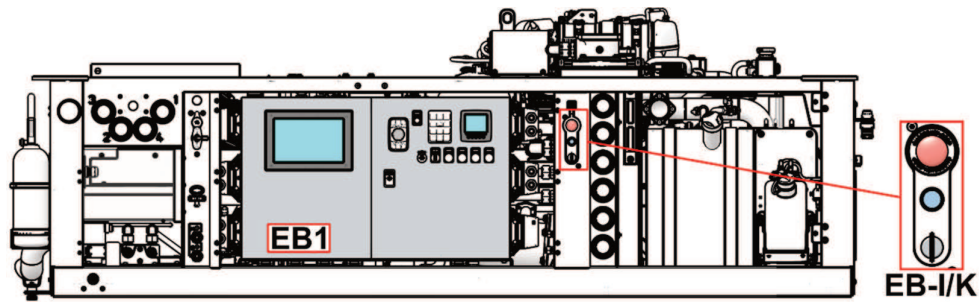

	[]	Position/Code of the component on the general system and identification plate on the vehicle.
		Component code.

Pos.	Description	
1a	Hydraulic steering block with 2 proportional valves (suspensions 1, 4).	[188.2077_1]
1b	Hydraulic steering block with 2 proportional valves (suspensions 5, 8).	[188.2077_2]
1c	Hydraulic steering block with 2 proportional valves (suspensions 9, 12).	[188.2077_3]
1d	Hydraulic steering block with 2 proportional valves (suspensions 10, 11).	[188.2077_4]
1e	Hydraulic steering block with 2 proportional valves (suspensions 6, 7).	[188.2077_5]
1f	Hydraulic steering block with 2 proportional valves (suspensions 2, 3).	[188.2077_6]
2	Hydraulic puller for mechanical vehicle coupling (optional).	309.5599.01
3	Hydraulic puller distributor.	[058.0373_1]
4	Inclinometers.	553.3288

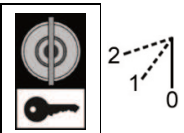
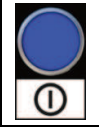
3.2. ELECTRIC PANELS



INDICATIVE FIGURE

Pos.	Description
[EB1]	<p>Main and power supply electric panel. Inside are the majority of electrical and electronic components, as for example:</p> <ul style="list-style-type: none"> • The machine computer. • The machine safety circuit computer. • The remote control unit X90. <p>On the outside are the control board, which allows to interact with the machine, and the cigarette-lighter type socket to connect the remote control battery charger to (see paragraphs 3.4 and 3.5).</p> 
[EB-I/K]	<p>Starting and enabling the machine can be done through the [EB-I/K] panel.</p> <div style="display: flex; align-items: flex-start;"> <div style="margin-right: 20px;">  </div> <div> <p>General key:</p> <ul style="list-style-type: none"> • Position 0 = OFF. • Position 1 (stable) = <u>[EB1] panel control board enabled.</u> • Position 2 (spring-return) = <u>Diesel engine start.</u> </div> </div> <hr/> <p>(INIT) button: vehicle enabling button.</p> <div style="display: flex; align-items: center; margin-top: 10px;">  </div> <p>ENABLING THE VEHICLE - OPERATING INSTRUCTIONS</p> <ul style="list-style-type: none"> • Connect the vehicle batteries → [+24V] switch lever in the [ON] position. • General key  in position 1. • The  button (INIT) starts flashing and the buzzer emits a warning sound/light indicating that the system is operational. Once the system is operational, press the  button (INIT); the button light is steadily lit. <p> NOTE For more instructions, refer to chapter 8.</p> 

3.3. HYDRAULIC TAPS

3.3.1 Power pack – Hydraulic taps

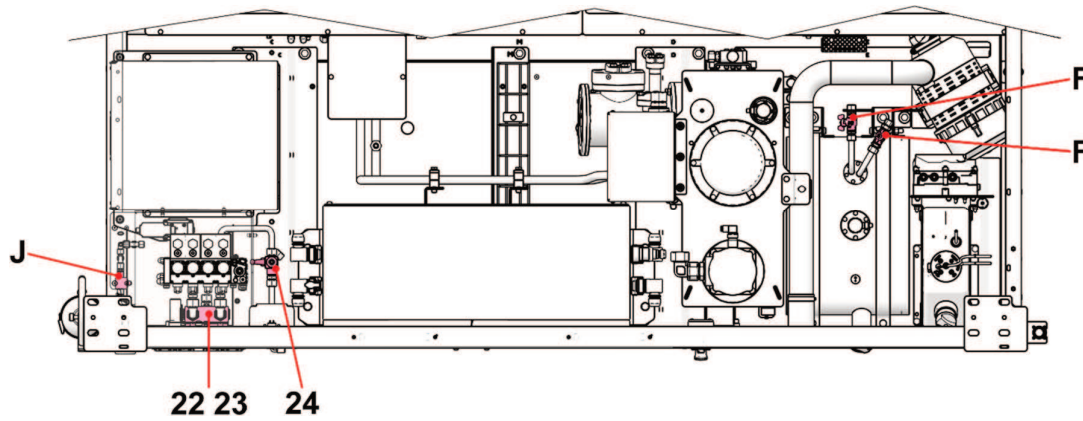
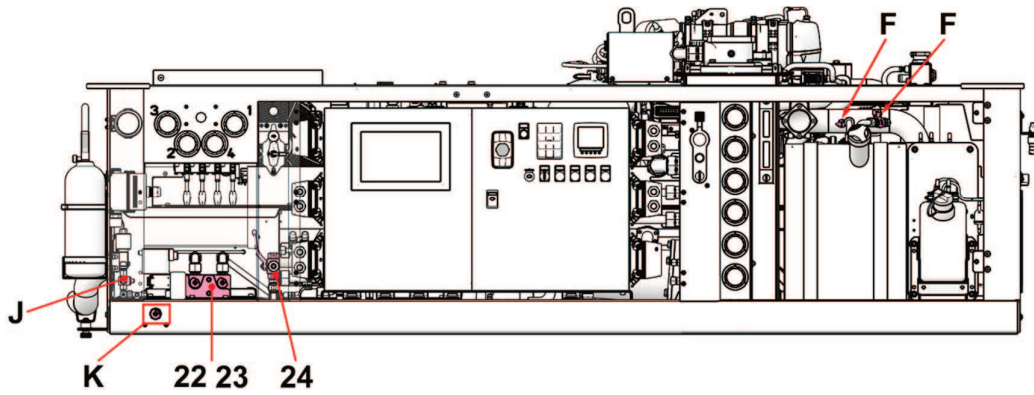

INDICATIVE FIGURE

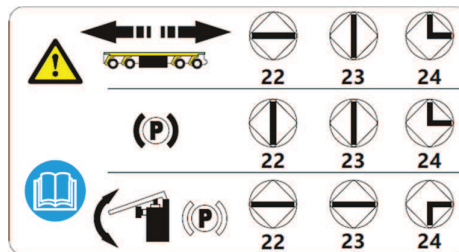

 [] Code of the tap on the general system and identification plate on the vehicle.

Pos.	Description
[F]	<p>Diesel engine maintenance taps (2 taps). The two taps must be open.</p> <p> ATTENTION <i>Close taps [F] when servicing the Diesel engine or filter.</i></p>

[147.0054_1]
[147.0054_2]

Continued →

Continued "Power pack – Hydraulic taps" →

Pos.	Description	
[J]	<p>Proportional valve tap (ELS) → Lifting and steering system.</p> <p>NORMAL OPERATING CONDITIONS Tap [J] in open position.</p> <p>EMERGENCY CONDITION The working pressure of the lifting and steering systems is controlled by the proportional valve (ELS). If the electronic system cannot control the valve (ELS) or the latter is faulty (no system pressure), tap [J] must be closed, thereby restoring the correct system pressure. See chapters 9 and 10.</p> <div style="border: 1px solid black; padding: 5px; display: inline-block;">  The icon lights up on the [EB1] electric panel and remote control displays when an error / fault in valve (ELS) functioning occurs. </div> <p>! ATTENTION <i>Close tap [J] only after turning on the Diesel engine and finding out a malfunction of valve (ELS). There's no pressure in the system while the Diesel engine is off.</i></p>	[147.0111_01]
[K]	<p>Hydraulic traction engines bypass tap → Motorization system.</p> <p>NORMAL OPERATING CONDITIONS Tap [K] in closed position.</p> <p>EMERGENCY CONDITION If the vehicle must be towed with the engine off (for example in case of engine failure), to avoid damaging the motorization system, tap [K] must be opened to bypass the hydraulic traction engines (see chapter 9).</p>	[147.0046_01]
[22]	<p>Parking brake taps.</p> <p>! ATTENTION <i>The taps must only be used in an emergency.</i></p> <p>NORMAL RUNNING With tap [22] closed and tap [23] open, the hydraulic oil reaches the brakes and the vehicle is controlled by the radio control.</p> <p>EMERGENCY BRAKE ENGAGED If taps are both open, the hydraulic brake oil is released and the vehicle is braked.</p> <p>EMERGENCY BRAKE RELEASE WITH EXTERNAL CONTROL UNIT If, in the event of a failure of the Diesel engine, it is necessary to release the brake, proceed as follows:</p>	[284.0230_1]
[23]	<ul style="list-style-type: none"> • Connect an external control unit to couplings [M] and [S] (on the right hand side of taps [22] and [23]). • Close both taps, [22] and [23]. • Connect the external control unit to the brake hydraulic circuit: push downwards the tap [24] lever (see summary plate on previous page). • Start the external control unit; the hydraulic oil will reach the brakes, releasing them. To brake the vehicle, open taps [22] and [23]. <p>NOTE <i>See chapter 9 for more information.</i></p>	
[24]	<p>Hydraulic circuit cut-off tap.</p> <p>Operate the tap to connect the coupling [M] to the brake circuit or the lifting and steering circuit, depending on the emergency procedure to be carried out:</p> <ul style="list-style-type: none"> • For emergency brake release, see chapter 9. • For emergency lifting and lowering of the vehicle, see chapter 10. 	[147.0179_01]

3.3.2 Vehicle ECO1000 – Hydraulic taps

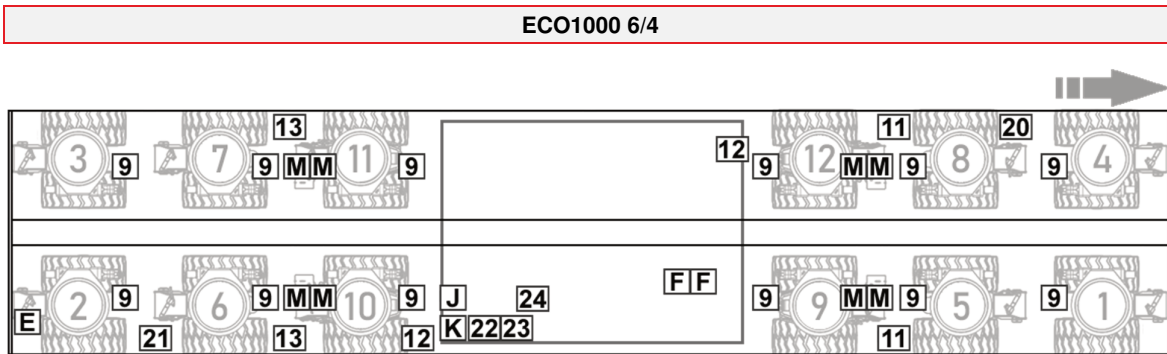

NOTE

Taps [F], [J], [K], [22], [23], [24] are on the power pack → see paragraph 3.3.1.



[] Code of the tap on the general system and identification plate on the vehicle.

Pos.	Description	
[E]	Hydraulic puller distributor tap. The tap must be opened before operating the hydraulic puller (optional).	[147.0111_01]
[M]	Motorized axle isolation taps (2 taps for each motorized axle) NORMAL OPERATING CONDITIONS Taps [M] in open position. MOTORIZED AXLE MECHANICAL DECOUPLING Taps [M] in closed position (see chapter 9). On the same ducts on which are installed the taps [M], there are two quick couplings that allow resetting the suspension hose burst valve after making a connection using the supplied mini-hose. For more information see chapter 10.	[147.0210_09] [147.0210_10] [147.0210_11] [147.0210_12] [147.0210_13] [147.0210_14] [147.0210_15] [147.0210_16]
[9]	Suspension cut-off tap [9]. TAPS [9] OPEN In normal operating conditions, all the taps [9] on the vehicle must be open. With the taps [9] open, the suspensions are connected to the relevant hydraulic point. TAPS [9] CLOSED <ul style="list-style-type: none"> • Before carrying out any maintenance operations, the taps [9] must be closed. • Before replacing a hydraulic hose, the relevant tap [9] must be closed. • Before replacing a tyre, the relevant tap [9] must be closed. <p>ATTENTION Keeping even a single tap [9] closed during operation of the vehicle can cause serious damage to the suspensions.</p>	[188.1832_1] [188.1832_2] [188.1832_3] [188.1832_4] [188.1832_5] [188.1832_6] [188.1833_1] [188.1833_2] [188.1833_3] [188.1833_4] [188.1833_5] [188.1833_6]
[11]	3/4 stability point selection taps.	[147.0210_01] [147.0210_02]
[12]	By opening or closing the taps, the vehicle can be set on 3 or 4 stability points. For more information see paragraph 10.6.	[147.0210_03] [147.0210_04]
[13]	<p>ATTENTION Set the vehicle to full low position before operating the taps: see chapter 10.</p>	[147.0210_05]
[20]		[147.0210_06] [147.0210_07]
[21]		[147.0210_08]

3.4. VEHICLE SOCKETS AND CONNECTORS

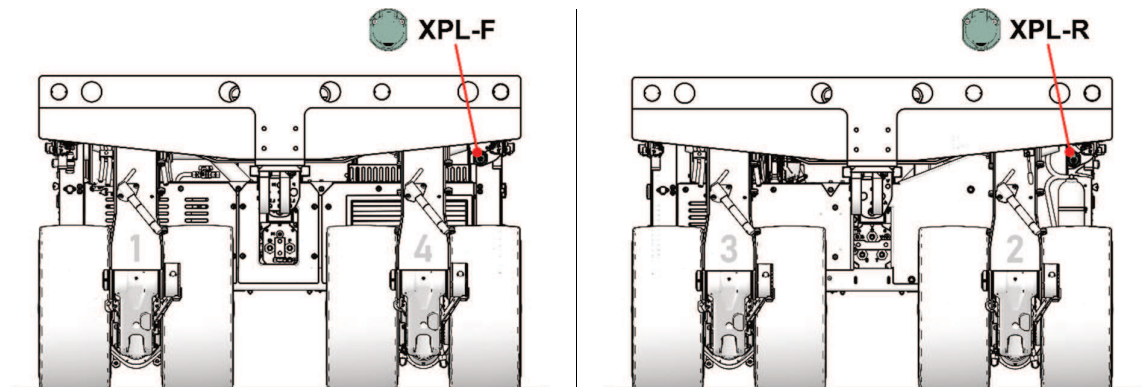
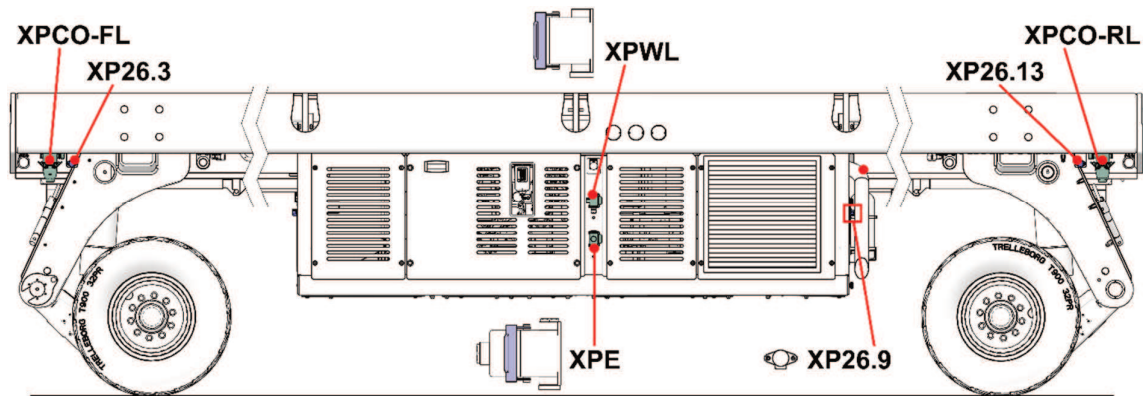
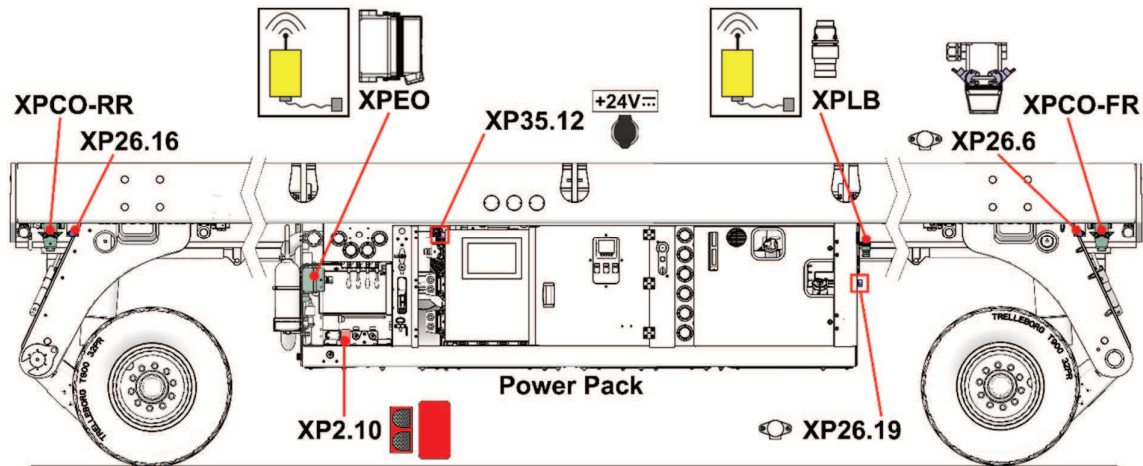





INDICATIVE FIGURE

Precautions for use

! **ATTENTION**
Unused sockets/connectors must be closed using the relevant plugs. Pay particular attention to cleaning the sockets and connectors before making a connection.

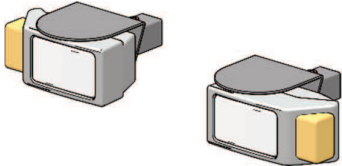
Continued →

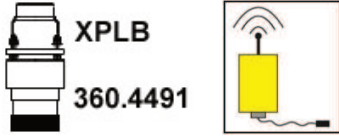







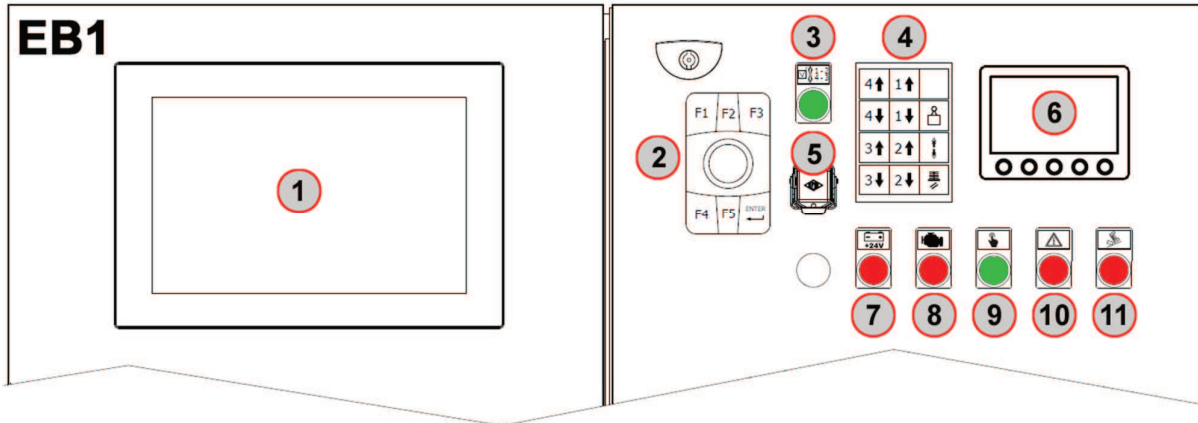

Continued →

Pos.	Description	Plug
[XP26.3] [XP26.6] [XP26.9] [XP26.13] [XP26.16] [XP26.19]	Portable lamp connection (360.4529). 	Yes
[XP2.10]	Jump Start system connection (emergency start-up in case of flat batteries).	Yes
[XP35.12]	Radio control battery charger connection.	Yes
[XPCO-FL] [XPCO-FR] [XPCO-RL] [XPCO-RR]	Electrical connection for coupled vehicles.	Yes
[XPCO-FL] [XPCO-FR]	Connection for removable lamps. ⁽¹⁾ 	Yes
[XPE]	Emergency button connection (360.2897). 	Yes
[XPEO]	Radio control receiver connection for emergency vehicle control.	Yes
[XPLB]	Radio control receiver connection. When the radio control receiver is not connected, the [XPLB] connector must be closed with the cap [360.4491]. 	Yes
[XPWL]	Suspension alignment pushbutton panel connection (360.1779). 	Yes

⁽¹⁾ = optional.

3.5. EB1 PANEL CONTROL BOARD



Pos.	Description
1	Touch screen display. The description of the display pages can be found in chapter 4. 
2	Electronic program navigation keyboard.  NOTE For more information, see paragraph 3.5.2. 
3	 Lifting and lowering commands enabling button. The lifting and lowering commands through keyboard (4) are enabled when the button is lighting. See the relevant instructions at chapter 10. 
4	Vehicle tare and lifting/lowering keyboard.  NOTE For more information, see paragraph 3.5.1. 
5	Ethernet connector.  ATTENTION <i>All works on the machine software and control parts shall be performed by Cometto S.p.A. technicians only or by personnel expressly authorised by Cometto S.p.A. Failure to comply with the aforementioned requirement will render the warranty void.</i>
6	Diesel engine diagnostics display. See all the specific information in the Diesel engine manufacturer's manual. Inside the same manual the list of error codes, which show up on this display, can be found. 
7	 Alternator warning light. The warning light lights up to indicate a fault/malfunction of the alternator fitted to the diesel engine, which may not recharge the engine's 12V batteries. Otherwise, illumination of the warning light is normal if the engine is switched off or in the first moments after starting.
8	 Engine diagnostics light. The light turns on to indicate a fault/malfunction of the Diesel engine. Look at the diagnostics display (6) for further information.

Continued →

Continued →

Pos.	Description	
9		Touch screen display command light. The warning light turns on whenever the touch screen display (1) detects a touch on it.
10		Main alarm indicator light. If the indicator light turns on for about 1" after enabling the control board, it is only a test to make sure that it is working properly. The presence of a main alarm is signalled by "fixed" switching on the indicator light. The type of error is indicated on the display by icons and/or texts.
11		Danger of overturning indicator light. If the indicator light turns on for about 1" after enabling the control board, it is only a test to make sure that it is working properly. The danger of overturning is signalled by "fixed" switching on the indicator light.

3.5.1 Vehicle tare and lifting/lowering keyboard

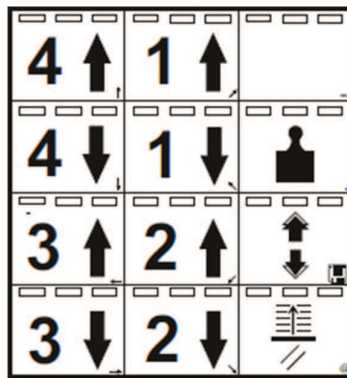

Precautions for use



























AVVERTENZA

Lifting or lowering a hydraulic point, with the vehicle on 4 stability points, make small movements to avoid torsion on the chassis.

Pos.	Description	
		Hydraulic lifting point 1.
		Hydraulic lowering point 1.
		Hydraulic lifting point 2.
		Hydraulic lowering point 2.





Continued →

Continued "Vehicle tare and lifting/lowering keyboard" →

Pos.	Description	
		 Hydraulic lifting point 3.
		 Hydraulic lowering point 3.
		 Hydraulic lifting point 4.
		 Hydraulic lowering point 4.
	DPF manual regeneration enabling. By pushing the key the Diesel particulate filter (DPF) manual regeneration is started. For more information, see paragraph 13.6. 	
	Tare weight. Press this key to reset the weight of the load placed on the vehicle. Examples: 1) By resetting the value when the vehicle is unloaded and then loading the vehicle, you will obtain the weight of the load; 2) By resetting the value each time a new load is added to the vehicle, you will be able to determine the weight of each load. <div style="border: 1px solid black; padding: 5px; display: inline-block;">  This box on the touch screen display indicates the transported load without the tare. </div>	
		Lifting and lowering limits bypass. Press and hold this key and operate, at the same time, at least one of the (point-to-point) lifting/lowering keys : <ul style="list-style-type: none"> • Lift the vehicle beyond the lifting limit switch. • Lower the vehicle beyond the lowering limit switch. • Lift and lower the vehicle when there is an error on the lifting system. The error is presented when the difference in height, between the highest point and the lowest point of the vehicle, is over 60 mm. A point is intended as the height detected on the external suspension equipped with a potentiometer. <div style="border: 1px solid black; padding: 5px; display: inline-block;">  Lifting and lowering limits bypass icon. </div> <div style="border: 1px solid black; padding: 5px; display: inline-block;">  System error icon. </div> <div style="display: flex; align-items: center;">  <p>ATTENTION <i>This function must only be used if strictly necessary and under the operator's full responsibility. As soon as possible, bring the system to normal working conditions.</i></p> </div> <div style="display: flex; align-items: center;">  <p>NOTE <i>For further information, see chapter 10.</i></p> </div> 
	Lifting/lowering system selection. Function not enabled.	

3.5.2 Electronic program navigation keyboard (keyboard F_)



Pos.	Description
F1	Keys to browse the screens of the electronic program. To access the keys function and browse the internal screens of the electronic program, the password must be used.  NOTE <i>There are multiple passwords for various levels of calibration and diagnostics. The machine manager must know the passwords and is in charge of their safekeeping and preservation.</i>  NOTE <i>For instructions on how to use the keys, refer to chapter 4.</i> 
F2	
F3	
F4	
F5	
ENTER 	Conferma inserimento dati nelle videate del programma elettronico.
	Rotary knob. Operate the knob to return to the previous screen.

Page intentionally left blank for DTP purposes.