

10

LIFTING AND LOWERING THE VEHICLE

CONTENTS

10.1.	LIFTING AND LOWERING MODE OF THE VEHICLE	10 - 2
10.2.	LIFTING AND LOWERING OPERATIONS WITH RADIO CONTROL	10 - 4
10.2.1	Point-to-point lifting/lowering via radio control.....	10 - 6
10.2.2	Total lifting/lowering via radio control.....	10 - 7
10.2.3	Equalisation of the loading platform.....	10 - 9
10.3.	LIFTING/LOWERING THE VEHICLE FROM THE CONTROL PANEL	10 - 10
10.4.	TOTAL LIFTING/LOWERING FUNCTION INHIBITION	10 - 12
10.5.	HYDRAULIC SUSPENSION	10 - 13
10.6.	STABILITY ON 3 AND 4 POINTS.....	10 - 14
10.6.1	Vehicle ECO1000 stability diagrams.....	10 - 17
10.6.2	Checking pressure on hydraulic points	10 - 18
10.6.3	Loading operations	10 - 20
10.6.4	Running operations.....	10 - 20
10.7.	HOSE BURST SAFETY DEVICES	10 - 21
10.7.1	Hose burst valve.....	10 - 21
10.7.2	Hose burst safety system	10 - 23
10.8.	LOWERING THE VEHICLE IN CASE OF A FAULT OF THE LIFTING/LOWERING SYSTEM.....	10 - 26
10.8.1	Electric system fault.....	10 - 27
10.8.2	Failure of the electrical system / Diesel engine / lifting and steering pump.....	10 - 28
10.9.	REPLACEMENT AND ELECTRICAL CALIBRATION OF A LIFTING POTENTIOMETER	10 - 32

10.1. LIFTING AND LOWERING MODE OF THE VEHICLE

Lifting and lowering mode of the vehicle

The vehicle can be lifted/lowered as follows:

- From the **radio control (transmitter)**, using the point-to-point or total function.



- From the **control panel**, using only the point-to-point function.

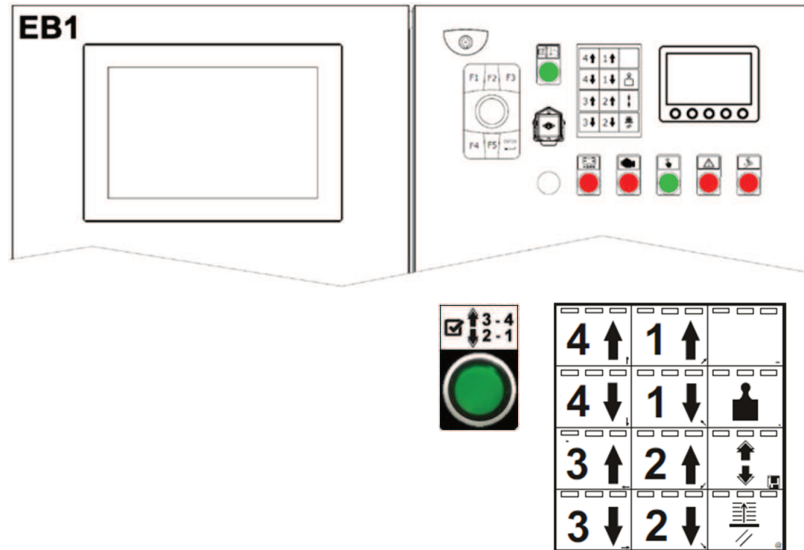

- From the **distributor block**, using only the point-to-point function.

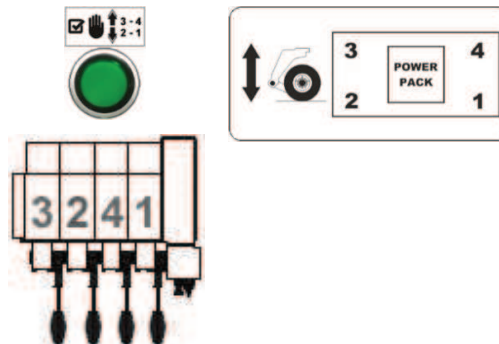

Continued →

Continued →

Precautions for use and safety

! ATTENTION
With suspensions completely lowered or completely raised, the vehicle can't be properly balanced.

! WARNING
Constantly check the pressure values of the hydraulic points; avoid exceeding 290 bar with the vehicle loaded (see the diagram in paragraph 10.6.2). During operation, these pressures can oscillate due to roughness of the ground. 

🔍 NOTE
The pressure at the hydraulic points is indicated on the radio control display, on the touch screen (control panel) and on the vehicle pressure gauges.

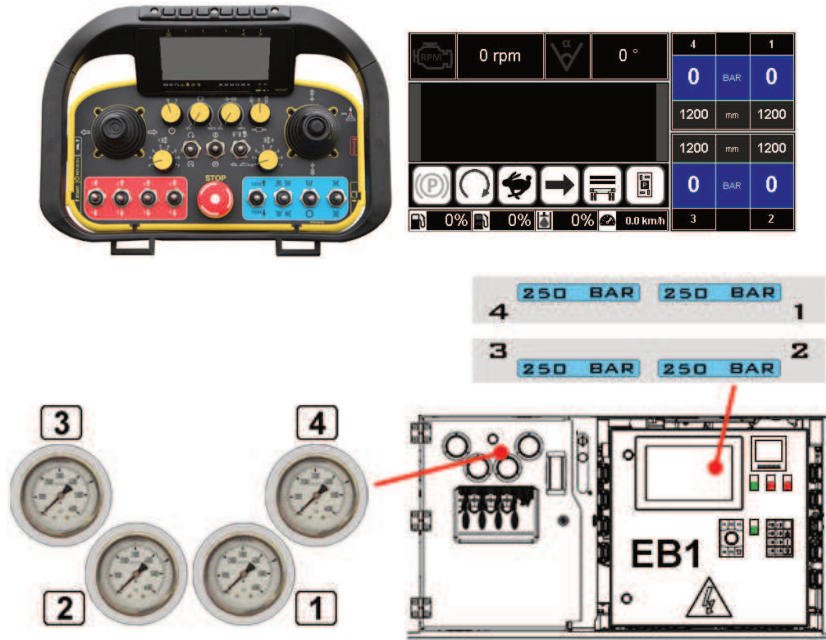

! WARNING
During lifting and lowering, make small changes in the position of the loading platform (on 3 or 4 stability points) until the desired height is reached.

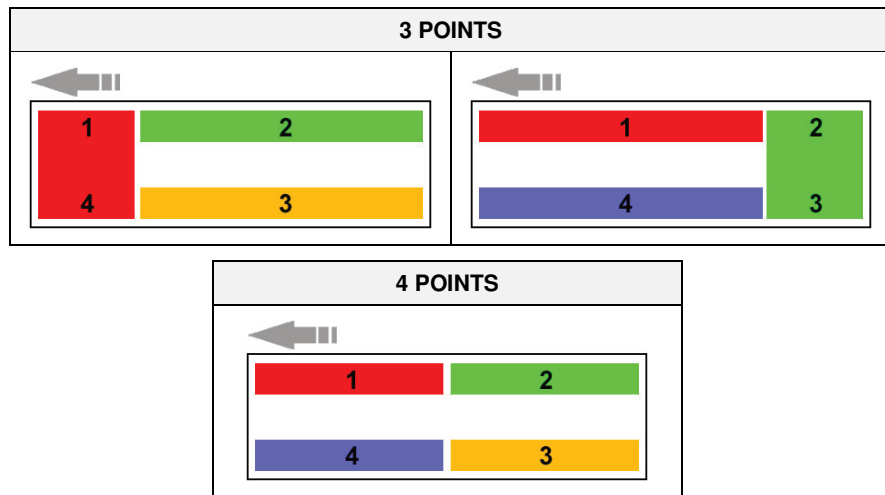

10.2. LIFTING AND LOWERING OPERATIONS WITH RADIO CONTROL

Connecting the receiver of the radio control

To ensure the operation of the radio control, connect the receiver to the [XPLB] connector via cable [360.4523].

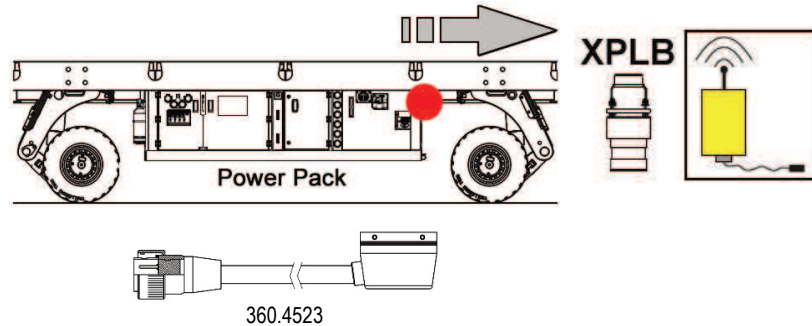

Safety precautions



WARNING

The radio control shall only be operated by properly trained personnel.



NOTE

Before all lifting and lowering operation, it is advisable to stop the vehicle and bring the travel direction selector switch in position "0".

Travel direction selector switch	
	REVERSE GEAR.
	0 NEUTRAL GEAR.
	FORWARD GEAR.

Manoeuvring speed

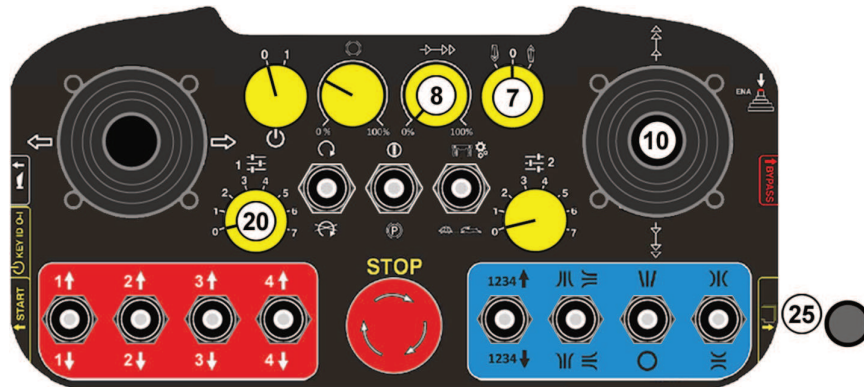

The speed of lifting and lowering manoeuvres depends on the speed of the Diesel engine. Please note the following:

- With the module in neutral gear (selector switch (7) in position 0) and the ECO mode active, the engine speed is kept fixed at the value set via the throttle adjustment potentiometer (8). Operate the potentiometer to change the manoeuvring speed.





NOTE

If the engine speed is too low, it may switch off when starting the lifting and lowering manoeuvres.

Continued →

Continued →

Manoeuvring speed

- With the module in neutral gear and ECO mode deactivated, the control software automatically and dynamically sets an engine speed that prevents it from being switched off during lifting and lowering operations. However, it is possible to increase the engine revs by moving the forward joystick (10); releasing it returns the engine revs to automatic control. In addition, the maximum limit that can be reached by action on the joystick can be changed with the potentiometer (8). To change the manoeuvring speed, use the joystick and, if necessary, the potentiometer.
- If the gear is engaged (selector switch (7) in position  – forward gear or in position  – reverse gear), the speed of the diesel engine is reduced to the minimum to keep it on during lifting and lowering operations.

**WARNING**

With the gear engaged, if the joystick (10) is operated, the vehicle moves in the selected driving direction.

**NOTE**

The ECO mode can be activated and deactivated using the selector switch (20) and the button (25). For further information on how to use the radio remote control, see Chapter 5.



10.2.1 Point-to-point lifting/lowering via radio control

Precautions for use

- !** **ATTENTION**
*It is forbidden to travel with the suspensions completely lowered or completely lifted.
The operating heights for the various load conditions can be found in paragraph 10.5.*
- !** **ATTENTION**
Operate the selector switches alternately, trying to balance the hydraulic point pressures between them. Pressure values can be checked via the transmitter display, the vehicle's pressure gauges or the touch screen display on the electrical cabinet [EB1].

Operating instructions

- 1) Start the Diesel engine (see chapter 8).
- 2) Release the parking brake: press and hold the button on the top end of the joystick (10) ("Dead man's" button) and operate the lever selector (3), then release both commands.

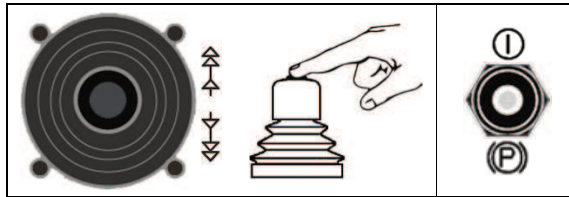

- 3) Operate the lever selectors as explained in the following:
 - 1) Press and hold selector switch 1 ↑ to lift hydraulic point 1.
Press and hold selector switch 1 ↓ to lower hydraulic point 1.
 - 2) Press and hold selector switch 2 ↑ to lift hydraulic point 2.
Press and hold selector switch 2 ↓ to lower hydraulic point 2.
 - 3) Press and hold selector switch 3 ↑ to lift hydraulic point 3.
Press and hold selector switch 3 ↓ to lower hydraulic point 3.
 - 4) Press and hold selector switch 4 ↑ to lift hydraulic point 4.
Press and hold selector switch 4 ↓ to lower hydraulic point 4.





During lifting/lowering the icon on the right-hand side lights up on the [EB1] panel and radio control displays.



Vehicle lifting/lowering is interrupted when:

- The selector is released.
- The lifting or lowering limit switch is reached.

LIFTING OR LOWERING THE VEHICLE BEYOND THE LIMIT SWITCHES

- Press and hold the BY-PASS button  and operate selector switch 1 ↑ or 2 ↑ or 3 ↑ or 4 ↑ to lift the corresponding point above the upper limit switch.
- Press and hold the BY-PASS button  and operate selector switch 1 ↓ or 2 ↓ or 3 ↓ or 4 ↓ to lower the corresponding point below the lower limit switch.

When the BY-PASS button is pressed, the icons on the right-hand side light up on the [EB1] panel and radio control displays.



10.2.2 Total lifting/lowering via radio control

Brief description

In the total lifting/lowering mode, the loading platform is kept parallel to the ground, i.e. all hydraulic points of the vehicle maintain approximately the same height above the ground (the height of the points is determined via the potentiometers mounted on the suspension [1], [2], [3] and [4]).

If, at the start of manoeuvring, the loading surface is not parallel to the ground, this results in:

- 1) During lifting, the lower points of the loading platform are raised first so as to reach the same level as the higher points.
- 2) During lowering, the higher points of the loading platform are lowered first so as to reach the same level as the lower points.

Precautions for use



ATTENTION

It is forbidden to travel with the suspensions completely lowered or completely lifted. The operating heights for the various load conditions can be found in paragraph 10.5.



ATTENTION

Before operating the selector switch, check that the hydraulic point pressures are nearly equal. The pressure values can be checked via the transmitter display, the vehicle pressure gauges or the electric panel [EB1] touch screen. When needed, to balance pressures raise or lower individual hydraulic points with the point-to-point function.

Operating instructions

During raising and lowering, the height of all suspensions is constantly monitored. To lift and lower the vehicle in total mode, follow the instructions:

- 1) Start the Diesel engine (see chapter 8).
- 2) Release the parking brake: press and hold the button on the top end of the joystick (10) ("Dead man's" button) and operate the lever selector (3), then release both commands.

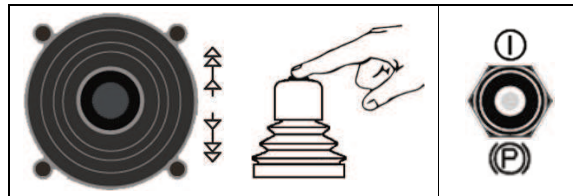

- 3) To lift or lower the loading platform, do the following:

- Operate and hold selector switch **1234** ↑ to lift the vehicle. During lifting, the icon on the right-hand side lights up on the [EB1] panel and radio control displays.
- Operate and hold selector switch **1234** ↓ to lower the vehicle. During lowering, the icon on the right-hand side lights up on the [EB1] panel and radio control displays.



Continued →



Continued "Total lifting/lowering via radio control" →

Operating instructions

By operating the selector switch, the vehicle is lifted / lowered parallel to the ground. Vehicle lifting/lowering is interrupted when:

- The selector is released.
- The lifting or lowering limit switch of one or more suspensions is reached.
- While lifting, the running height (1500 mm) is reached. The latter is the mean value of the heights of the four outer suspensions, which are equipped with potentiometers. It's an indicative value since it depends on the vehicle tilt. Release and operate again the controls to lift further.
- A height difference of at least 60 mm is registered between two or more suspensions equipped with potentiometers (lifting system error).

LIFTING OR LOWERING THE VEHICLE BEYOND THE LIMIT SWITCHES AND/OR WITH THE LIFTING SYSTEM ERROR

- Press and hold the BY-PASS button  and operate selector switch **1234** ↑ to keep lifting the vehicle.
- Press and hold the BY-PASS button  and operate selector switch **1234** ↓ to keep lowering the vehicle.

When the BY-PASS button is pressed, the icons on the right-hand side light up on the [EB1] panel and radio control displays.



10.2.3 Equalisation of the loading platform

Brief description

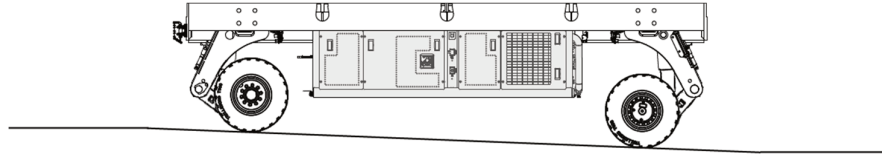

The equalisation of the loading platform allows it to be levelled and kept level regardless of the slope of the terrain both in static conditions and during transport.



INDICATIVE FIGURE

Act on the relevant switch (6) to activate the function: push it upwards to alternately activate/deactivate the mode.



	<p>When the mode is active, the icon on the left-hand side lights up on the [EB1] panel and radio control displays.</p>
	<p>When the mode is not active, the icon on the left-hand side lights up.</p>

The function cannot be activated if there is a height difference of at least 60 mm between two or more suspensions equipped with a potentiometer (lifting system error). To get out of the error condition, use point-to-point lifting/lowering as described in paragraph 10.2.1.



The function is automatically deactivated when:

- The lifting system error occurs during levelling the platform.
- The lifting or lowering limit switch of one or more suspensions is reached during levelling.
- Any of the lifting and lowering selectors described in paragraphs 10.2.1 and 10.2.2 above are actuated.

10.3. LIFTING/LOWERING THE VEHICLE FROM THE CONTROL PANEL

Preliminary information

When the radio control is not operational, the vehicle can be lifted and lowered using the appropriate keyboard on the control board of the vehicle, on the electric panel [EB1].

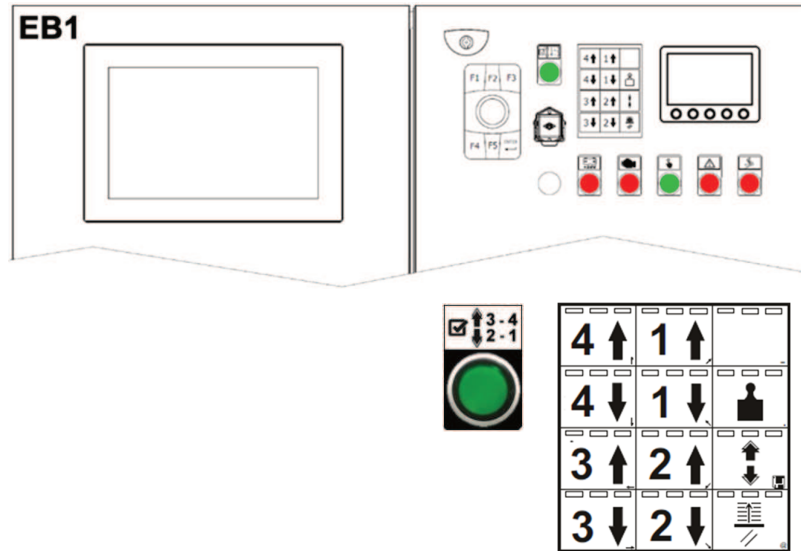

First, disconnect the radio control receiver from the connector [XPLB] and close it with the cap [360.4491].

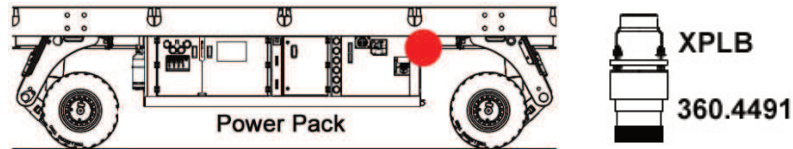

Precautions for use



NOTE
The total lifting/lowering function is not available on the control panel.



ATTENTION
Operate the keys alternately, trying to balance the hydraulic point pressures between them. Pressure values can be checked via the vehicle's pressure gauges or the touch screen display on the electric panel [EB1].



WARNING
The command and control functions of the vehicle are limited compared to those offered by the radio control.













WARNING
The lifting/lowering commands from the keyboard on the control board can be enabled and used even when the radio control is operational and correctly connected to the vehicle. However, this practice is discouraged: where possible, always use the radio control as it offers all the command and control functions of the vehicle and allows you to remain at a distance from it during manoeuvres.

Continued →

Continued →

Operating instructions

- 1) Start the Diesel engine through the panel [EB-I/K] (see chapter 8). 
- 2) Press button   1-2-3-4 to enable the lifting controls; when the controls are enabled, the button light is on.
- 3) Act on the buttons as shown below:
 - Press and hold key 1  to lift hydraulic point 1.
Press and hold key 1  to lower hydraulic point 1.
 - Press and hold key 2  to lift hydraulic point 2.
Press and hold key 2  to lower hydraulic point 2.
 - Press and hold key 3  to lift hydraulic point 3.
Press and hold key 3  to lower hydraulic point 3.
 - Press and hold key 4  to lift hydraulic point 4.
Press and hold key 4  to lower hydraulic point 4.









During lifting/lowering the icon on the right-hand side lights up on the [EB1] panel and radio control displays.



Vehicle lifting/lowering is interrupted when:

- The enabling button is pressed again and the light switches off.
- The key is released.
- The lifting or lowering limit switch is reached;

LIFTING OR LOWERING THE VEHICLE BEYOND THE LIMIT SWITCHES

- Press and hold together the BY-PASS key on the keyboard and the keys 1  or 2  or 3  or 4  to lift the corresponding point above the upper limit switch.
- Press and hold together the BY-PASS key on the keyboard and the keys 1  or 2  or 3  or 4  to lower the corresponding point below the lower limit switch.

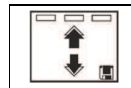

BY-PASS key on the keyboard.



When the BY-PASS key is pressed, the icons on the right-hand side light up on the [EB1] panel and radio control displays.



10.4. TOTAL LIFTING/LOWERING FUNCTION INHIBITION

Description

Total lifting/lowering of the vehicle is not allowed if the lifting system error occurs. It happens when the height difference between the highest and the lower points of the vehicle is at least 60 mm. Both [EB1] panel and radio control displays show, in the specific screens, the error icon and the inhibited total lifting/lowering icon.

Lifting system error icon	Inhibited total lifting/lowering icon
	

Use the point-to-point function to level the point heights and exit the error condition. Make use of:

- Point heights are indicated in the main screens of [EB1] panel and radio control displays.
- The green-lined stability polygon on the [EB1] panel display. The vertices represent the point heights: when the latter are uniform, the polygon has a regular shape.

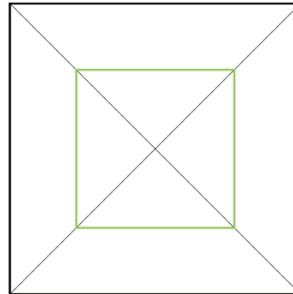

INDICATIVE FIGURE

Otherwise, the polygon assumes an irregular shape.

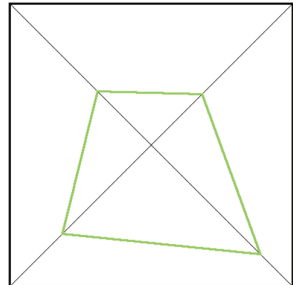

INDICATIVE FIGURE

10.5. HYDRAULIC SUSPENSION

Preliminary information

The vehicle is equipped with hydraulic type suspensions which are particularly suitable for vehicles with considerable load capacity.

Technical specifications

SUSPENSIONS STROKE AND OPERATING CONDITIONS

The total stroke of the suspensions is 700 mm. For better use of the vehicle, consider a usable suspension stroke of 600 mm (+350 / -250).

The height of the vehicle under operating conditions is:

- 1500 mm (with load).
- 1540 mm (with no load).

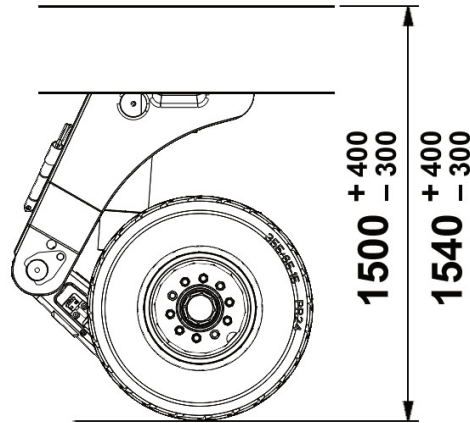

Safety standards



ATTENTION

It is forbidden to travel with the suspensions completely lowered or completely lifted.

Furthermore, during operation, utmost attention must be paid when crossing over obstacles, bumps on the road, etc.

10.6. STABILITY ON 3 AND 4 POINTS

General description

The load that the vehicle carries is distributed over the suspensions, which in turn can be grouped into three or four suspension units. In every unit, the suspensions are hydraulically connected to each other. These units allow setting the vehicle on 3 or 4 stability points.

3 STABILITY POINTS

In this condition, the vehicle has an isostatic support on 3 points. It cannot overturn if the total centre of gravity (vehicle + load) is at the centre of the indicator.

This is the recommended stability mode.



WARNING

The ECO1000 2/2 is an exception, for which it is preferable to adopt the 4-point stability support (see below).

Two 3-point stability conditions can be defined, which differ according to how the 3 points are arranged:

- CASE 1: single front point, rear shoulders (relative to the travel direction).



For the point-to-point lifting and lowering of hydraulic point (1 - 4), use:

- Selector switch 1 or 4, if the operation is carried out from the radio control.
- Keys 1 ↑ and 1 ↓ or 4 ↑ and 4 ↓, if the operation is carried out from the control panel.
- The lever of distributor 1 or 4, if the operation is carried out using the distributor block (see paragraph 10.8). 

- CASE 2: single rear point, front shoulders (relative to the travel direction).

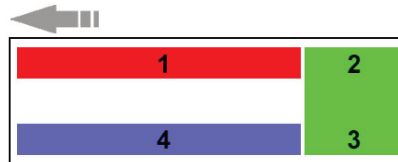

For the point-to-point lifting and lowering of hydraulic point (2 - 3), use::

- Selector switch 2 or 3, if the operation is carried out from the radio control.
- Keys 2 ↑ and 2 ↓ or 3 ↑ and 3 ↓, if the operation is carried out from the control panel.
- The lever of distributor 2 or 3, if the operation is carried out using the distributor block (see paragraph 10.8). 

4 STABILITY POINTS

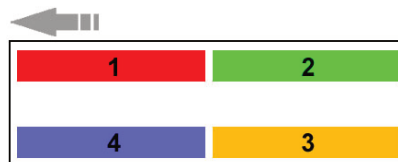

WARNING

Use of the loaded vehicle on 4 stability points is only permitted when there are no irregularities on the ground, if the road is flat and if the pressures in the points are very close.



WARNING

For ECO1000 2/2 vehicles, given the small number of suspensions, this is the type of support that should preferably be chosen to ensure greater vehicle stability.

Continued →

Continued →

Cut-off taps

The suspensions can be grouped into units using the cut-off taps, [11] (2 units) – [12] (2 units) – [13] (2 units) – [20] – [21], of the vehicle hydraulic system, located on the edge of the frame. The stability diagrams in the next page show the suspension units, the position of the taps and which of them to close in order to obtain a specific stability set-up.



NOTE

Depending on the ECO1000 vehicle model, not all cut-off taps are provided on the vehicle. Please refer to the stability diagrams.

Stability characteristics

The vehicle is stable when the position of the centre of gravity of the load is at the centre of the indicator displayed on the touch screen.



WARNING

When the projection of the centre of gravity is close the edge of the indicator, the vehicle tilts dangerously and the load can tip over. DANGER OF OVERTURNING THE LOAD!!



ATTENTION

The danger of overturning is due to a significant difference in pressure between the hydraulic points. Balance the pressure values as soon as possible to restore the centre of gravity of the load as far as possible to the centre of the indicator.

When there is a risk that the load could overturn, the operator receives the following warnings:

- The buzzer emits a warning sound and its light turns on.

INDICATIVE FIGURE

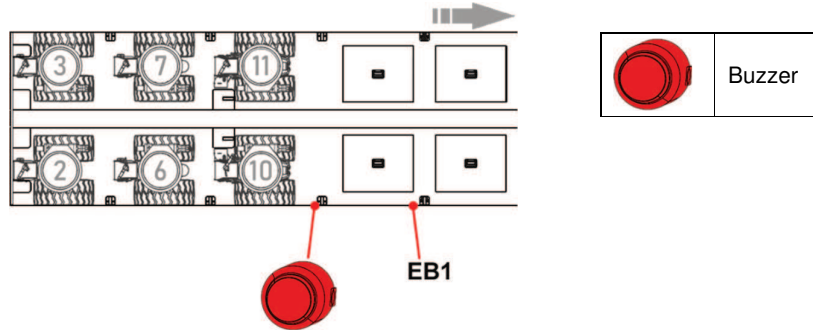

- The vehicle's side lights flash.

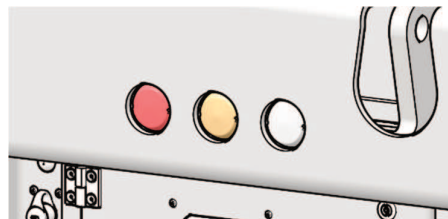

Continued →

Continued "Stability on 3 and 4 points" →

Stability characteristics

- The overturning hazard indicator light on electric cabinet [EB1] turns on.

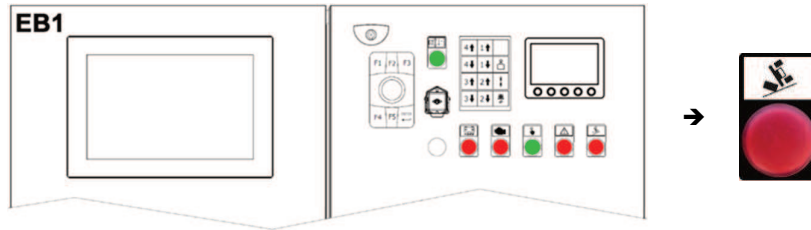

- An overturning hazard icon is displayed on electric cabinet [EB1] (main page) and on the radio control (machine status icons page).
- The general error indicator light below the radio control display turns on/starts flashing.



Stability management

If the pressure values are equal, the centre of gravity of the load is at the centre of the indicator.
On the touch screen display, in the white pane below the indicator, the polygon described by the light blue lines has a regular shape.

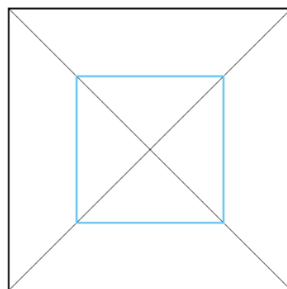

INDICATIVE FIGURE

The stability of the vehicle decreases as the pressure at any of the hydraulic points decreases; under these conditions, the centre of gravity of the load moves towards the edge of the indicator opposite to the point where there is a decrease in pressure. The polygon takes an irregular shape.

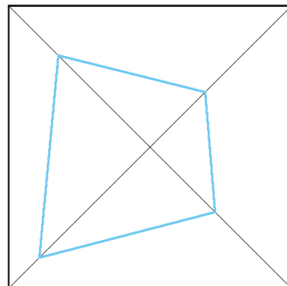

INDICATIVE FIGURE

The pressure values can be rebalanced using the point-to-point function available on the radio control to lift/lower each hydraulic point individually.



WARNING

When there is a danger of overturning, keep any persons and/or objects away from the vehicle, stay at a safe distance and use the radio control to operate the machine.

10.6.1 Vehicle ECO1000 stability diagrams

Preliminary information

To set the vehicle on 3 or 4 stability points, operate the hydraulic taps located on the outer edge of the vehicle, below the loading platform, by hand. The following diagrams show which taps should be opened/closed in order to obtain the two stability set-ups (on 3 or on 4 stability points).

The stability set-up can be changed if:

- When switching from case 1 to case 2 on 3 stability points: the maximum pressure difference between two adjacent points is < 50 bar.
- When switching from 3 to 4 stability points: the maximum pressure difference between two adjacent points is < 30 bar.
- When switching from 4 to 3 stability points: the maximum pressure difference between two adjacent points is < 50 bar.

If the differences exceed the values indicated above, use the point-to-point function to operate each hydraulic point individually in an attempt to achieve a better balance between the pressure values.



WARNING

Set the vehicle to full-low position before making any changes in the stability set-up: risk of unexpected vehicle movement.



ATTENTION

To avoid unnecessary torsion stresses on the chassis, use is preferred of the vehicle in the 3-point stability condition. The ECO1000 2/2 is an exception: given the small number of suspensions, the 4-point condition is recommended as it guarantees greater stability.



ATTENTION

Do not mistake these taps for the suspensions taps [9]. Keeping even a single tap [9] closed during operation of the vehicle can cause serious damage to suspensions.

ECO1000 6/4

Set the taps as follows:

- 3 STABILITY POINTS – CASE 1

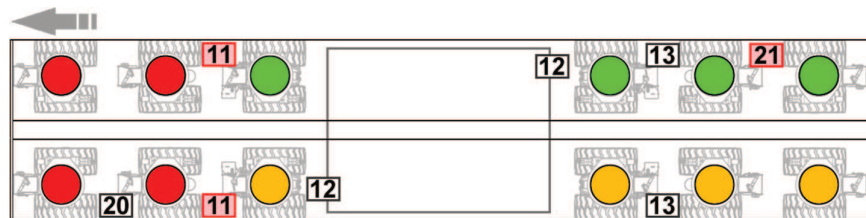

- 3 STABILITY POINTS – CASE 2

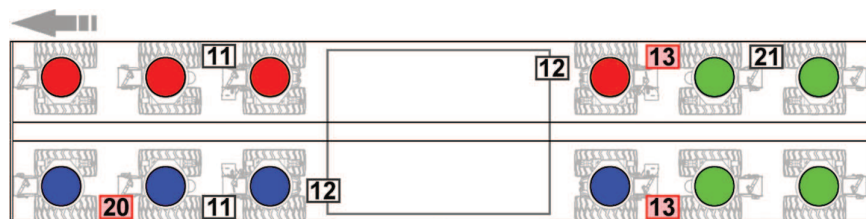

- 4 STABILITY POINTS

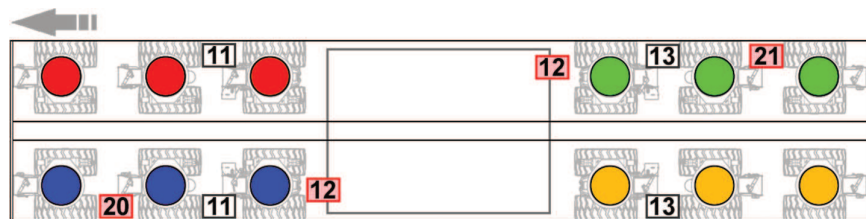

Tap CLOSED

10.6.2 Checking pressure on hydraulic points

General description

The “Diagram of load / pressures with suspensions at half stroke” express the relation between the pressure read in the cylinders of the suspensions and the useful load, when the suspensions are approx. half stroke.

The useful payload corresponding to a hydraulic point is calculated by multiplying the value read on the diagram by the number of suspensions belonging to the point.

The right of the diagram outlines the overall weight, the total useful payload and dead weight.

Overload

An overload condition occurs when one or more hydraulic points exceed the rated load for a long enough time to avoid false alarms due to, for example, road surface roughness. The operator receives the following reports:

- The buzzer sounds and lights up.

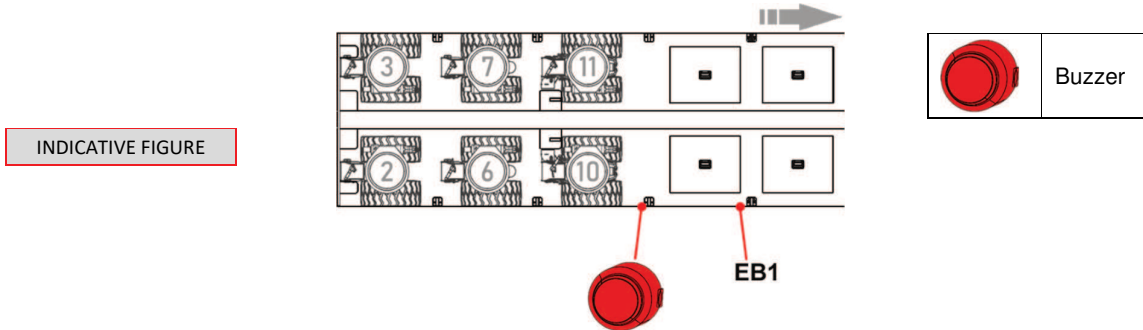

- The vehicle's side lights flash.



- The overload icon appears on the displays of the electrical cabinet [EB1] (main page) and radio control (machine status icon page).
- The general error indicator light below the radio control display turns on/starts flashing.



Safety warnings



WARNING

For a safe use of the tyres, pay attention to the different speeds that change depending on the load-bearing capacity.



ATTENTION

An excessive load for the axle line can damage the ground; therefore the latter must be checked that is suitable to resist stresses before undertaking transport.

Continued →

Continued →

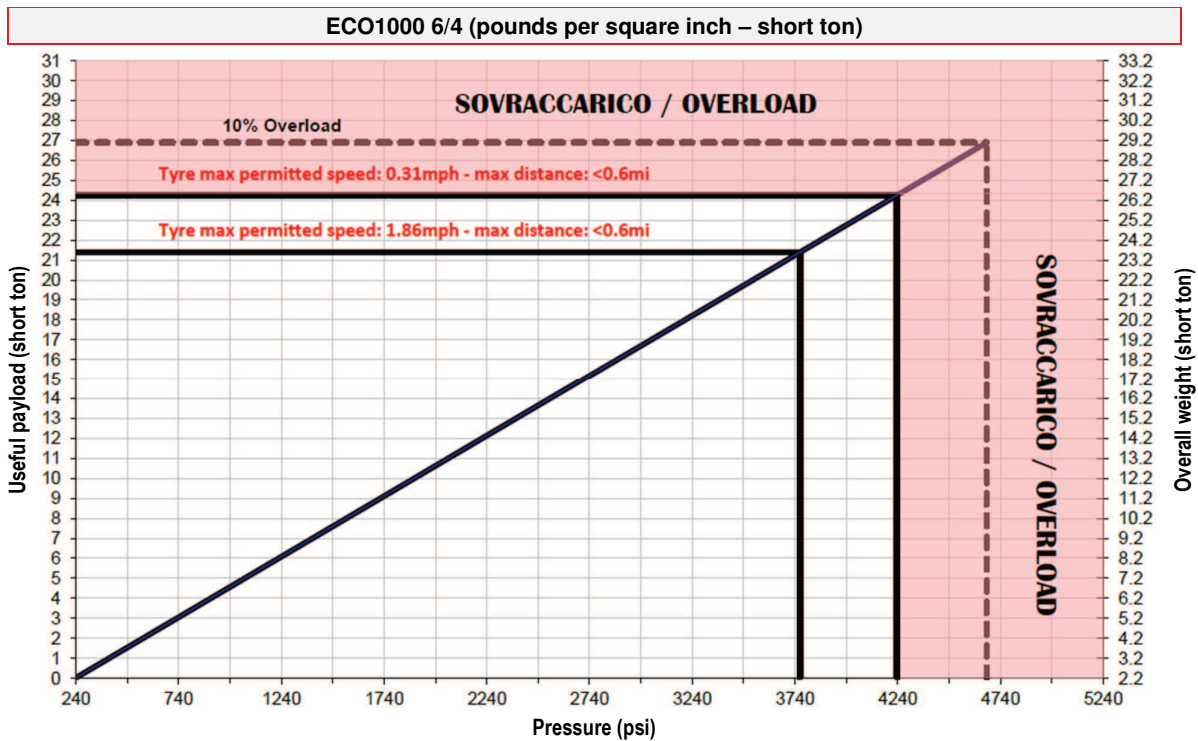
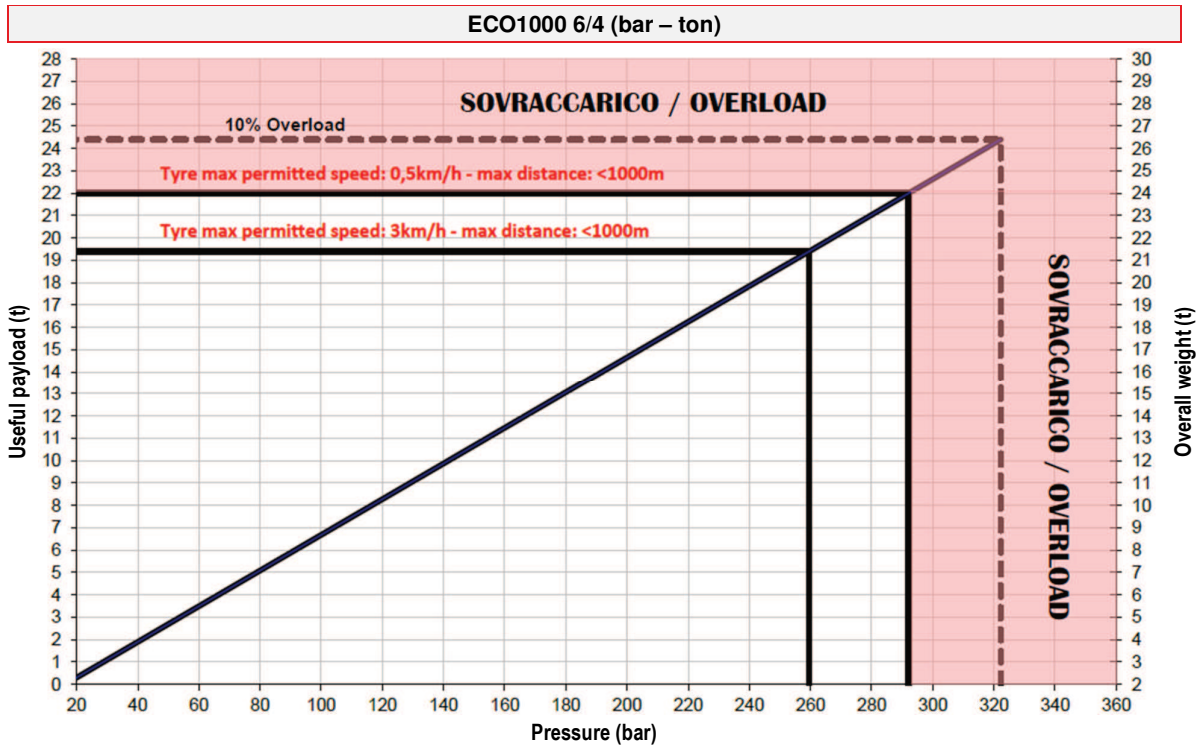

SPEEDS / WEIGHTS	ECO1000 6/4	
Maximum speed	0,5 km/h – 0.31 mph	3 km/h – 1.86 mph
Overall weight	288000 kg – 634931.3 lb	256800 kg – 566800 lb
Useful payload	264000 kg – 582020.4 lb	232800 kg – 513236.1 lb

10.6.3 Loading operations

Operating instructions

- Load positioning should be carried out by trying to balance the pressure between the hydraulic points. The loading areas are indicated in  paragraph 2.4.
- The pressure value of each point must be under 290 bar with suspensions at half-stroke.

10.6.4 Running operations

Preliminary information



WARNING

The conditions of the road surface can cause variations in load distribution on the hydraulic points; therefore, pay attention to any changes in the pressure indicated on the radio control display, the touch screen (control panel) display and the pressure gauges installed on the vehicle.

In any case, the following conditions shall be verified.

STABILITY CONDITION ON 3 POINTS

- Maximum allowable pressure in one point: $p_{max} = 290$ bar.
- Maximum pressure difference between 2 adjacent points: $(\Delta p)_{max} = 50$ bar.

Example: if point 1-4 detects a pressure of 100 bar, point 2 and point 3 shall not exceed 150 bar or be less than 50 bar.



If these conditions are exceeded while driving, it is necessary to level the vehicle, raising or lowering point by point, until the pressure balance is reached.

STABILITY CONDITION ON 4 POINTS

- Maximum allowable pressure in one point: $p_{max} = 290$ bar.
- Maximum pressure difference between 2 adjacent points: $(\Delta p)_{max} = 30$ bar.

Example: if point 1 detects a pressure of 100 bar, point 2 and point 4 should not exceed 130 bar or be less than 70 bar.



If these conditions are exceeded while driving, it is necessary to level the vehicle, raising or lowering point by point, until the pressure balance is reached.

Safety warnings



WARNING

The maximum pressure inside a hydraulic point corresponds to the maximum range of tyres and rims. An additional overload can therefore cause serious damage to both the suspension and the tyres, putting at risk the safety of transport.

10.7. HOSE BURST SAFETY DEVICES

Preliminary information

In case of burst of the connection hose between the suspension and the vehicle hydraulic system, the hose burst safety devices prevent a suspension to collapse and they stop the uncontrolled oil spill.

All different ECO1000 types are equipped with hose burst valves out of the ECO1000 2/2, which is provided with hose burst safety systems made of more valves and hoses.

10.7.1 Hose burst valve

Brief description

Each suspension is equipped with a hose burst valve that trips if the hose connected to the lifting cylinder of the suspension bursts.

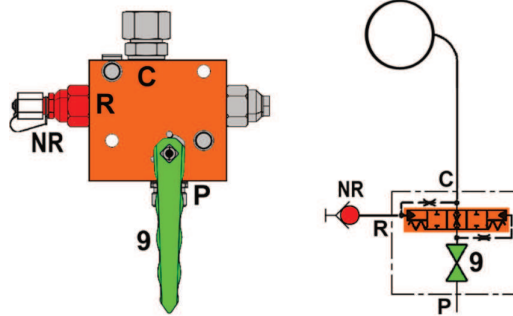

Precautions for use and safety



ATTENTION

Operation of the hose burst valve is guaranteed for 24 months. The valve is a safety system and as such should never be tampered with. Any tampering with the valve causes the warranty to expire and can prejudice its operation.

The presence of a hose burst valve does not exempt the user from the responsibility of checking and maintaining the hoses in a state of perfect efficiency and intact.

Hydraulic hoses should be replaced according to the SAE J1273 standard.



ATTENTION

To avoid unnecessary interventions of the hose burst valve, avoid crossing bumps and dips at high speed.



ATTENTION

If a hose burst valve trips even if the hose did not burst, the stability of the convoy may be affected.



NOTE

Check the pressure at the hydraulic points during transport. The pressure on the hydraulic points must be as equal as possible.

Significant differences might be due to an intervention of the hose burst valve.

Continued →

Continued "Hose burst valve" →

Intervention of the hose burst valve and its resetting

The hose burst valve (V) is normally open; it allows free passage of the oil from the line (P) to the lifting cylinder (HC) and vice versa.

If the hose connecting the hydraulic line to the suspension cylinder bursts, the hose burst valve closes, cutting off the oil supply to the cylinder and preventing an uncontrolled tilting of the vehicle, which may lead to load overturning.

In case of intervention (closing) of the valve, if you are in a safe condition, you must:

- Connect a mini-hose between the pressure outlet (TM) next to the taps [M] of the motorisation hydraulic circuit (two taps [M] for each motorised suspension) and the pressure outlet (NR) of the valve to be reset. The mini hose (code 186.2857) comes with the tool box.
- Start the Diesel engine.
- Wait a few seconds.
- Turn off the Diesel engine.
- Disconnect the mini-hose.
- Cover the pressure outlets with the relevant plugs.

At this point, the hose burst valve is operational again.

INDICATIVE FIGURE

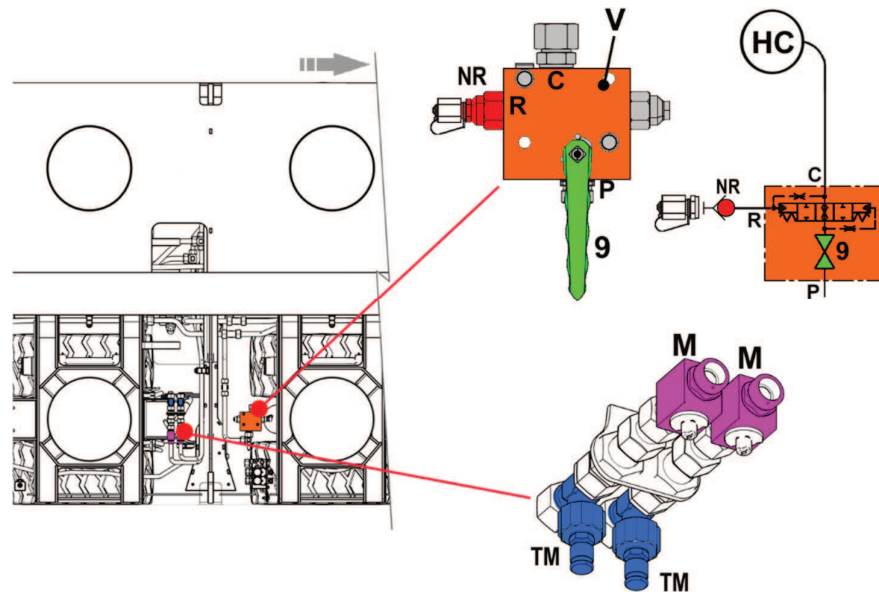

Precautions for use and safety



ATTENTION

A malfunctioning hose burst valve (example: valve not reset) can cause breakage of the hydraulic cylinder or parts of the suspension. Therefore, before undertaking transport, always check the hose burst valves are set, i.e. connection is guaranteed between the line and the cylinder.

10.7.2 Hose burst safety system

Brief description

Each suspension cylinder is connected to the hydraulic system with two hoses, which are protected in case of burst by two safety valves: one on the cylinder side, the other on the main hydraulic system side

INDICATIVE FIGURE

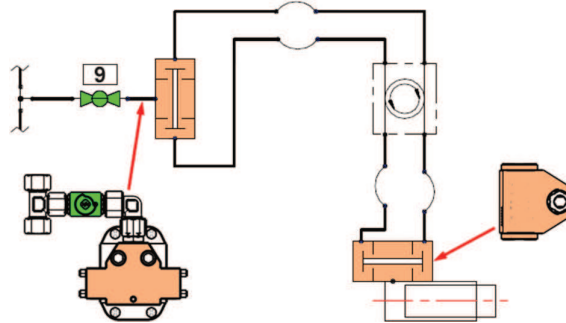

Intervention of the hose burst safety system

Both valves of the hose burst safety system have a spool inside, which can arrest the oil flow going through them. Their intervention occurs with a certain delay, in order to avoid undesired oil-flow stops during common dynamic functioning of the suspensions (e.g.: immediate pressure fall due to a suspension suddenly entering a pothole).

The burst of one of the two hoses connecting the suspension to the hydraulic system implies a sudden and unexpected rise of the oil flow, which spills out of the broken hose, but also makes the spool of both valves move and plug the ends of the broken hose. The second hose is still functioning and keeps the suspension cylinder connected to the hydraulic system.

The use of these valves has two advantages:

- Immediate stop of the oil spillover.
- Vehicle manoeuvring can still be carried out effectively.

Continued →

Continued "Hose burst safety system" →

Resetting the hose burst safety system

- 1) Before changing the broken hose, turn on the engine (see chapter 8).
- 2) Set the vehicle at running height (see chapter 10) and secure it: attach four chains of adequate capacity to the four lifting points on the frame.  The vehicle does not have to be lifted, but the loading platform must be kept horizontal in the event of a burst of a second hose.



WARNING

The ECO1000 2/2 vehicles stand on four suspensions only: in case of burst or accidental loss of a second hose, the safety system might not be able to stop the uncontrolled oil spillover and the vehicle may tilt over the suspension with the broken hoses.

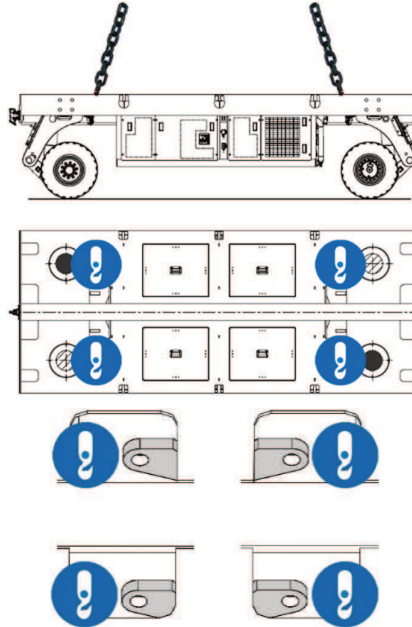

- 3) Switch off the engine and the control board: general key  in position "0".

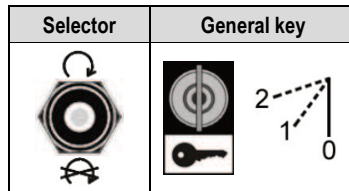

- 4) Close tap [9] of the suspension with the hose to be replaced: the suspension is now isolated from the hydraulic main circuit.

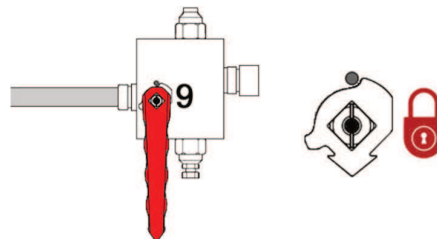

- 5) Replace the broken hose.

Continued →



Continued →

Resetting the hose burst safety system

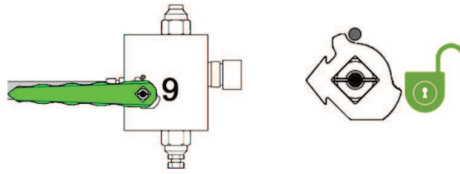
- 6) Open tap [9].

**ATTENTION**

To avoid unnecessary interventions of the hose burst safety system, avoid crossing bumps and dips at high speed.

- 7) Start again the engine.
- 8) In order to reset the valve spools in normal position and let the oil flow through the new hose, set the vehicle to all-low position (see chapter 10). Follow the lowering with the crane and the securing chains. 
- 9) Keep the vehicle in all-low position for about 3-4 seconds.
- 10) The hydraulic-system/cylinder connection has now been reset for both hydraulic hoses. Set the vehicle to running height again.
- 11) Switch off the engine and the control board: general key  in position "0".
- 12) Remove the chains.

Precautions for use and safety**NOTE**

Check the pressure at the hydraulic points during transport. The pressure on the hydraulic points must be as equal as possible. Significant differences might be due to an intervention of the hose burst safety system.

**ATTENTION**

The valves are essential parts of the hose burst safety system and as such should never be tampered with. Any tampering with the valves can prejudice the operation of the whole system.

The presence of a hose burst safety system does not exempt the user from the responsibility of checking and maintaining the hoses in a state of perfect efficiency and intact.

Hydraulic hoses should be replaced according to the SAE J1273 standard.

**ATTENTION**

To avoid unnecessary interventions of the hose burst safety system, avoid crossing bumps and dips at high speed.

**ATTENTION**

If a hose burst valve trips even if the hose did not burst, the stability of the convoy may be affected.

**WARNING**

As an intervention of the hose burst safety system occurs, replace the broken hose and reset the safety system as soon as possible. If not, in case of burst of a second hose on the same suspension, this may lead to dangerous stability conditions of the vehicle.

**WARNING**

Replace a hose only on an empty vehicle.

10.8. LOWERING THE VEHICLE IN CASE OF A FAULT OF THE LIFTING/LOWERING SYSTEM

Preliminary information

In the event of a fault to the lifting/lowering system, it is still possible to change the height of the vehicle hydraulic points via the lift/lowering distributor block, proceeding point-by-point.

If the lifting and steering pump is unusable (due to a failure or because it cannot be activated), to release the parking brake and to perform the lifting/lowering operations the following must be used, according to what components are installed on the power pack:

- A) The hand pump directly installed on the power pack.
- B) An external auxiliary pump (not provided), by connecting it to the couplings [M] and [S] on the power pack. The auxiliary external pump can be:
 - A hand pump.
 - An electro-pump complying with the characteristics shown in the table below.

Auxiliary pump characteristics	
Needed pressure	200 - 250 bar
Flow rate	≈ 10 l/min

Preliminary information



WARNING

Before carrying out the emergency lowering procedure, ensure the vehicle's surrounding area is free of people and/or property.



ATTENTION

Operate the levers alternately, trying to balance the hydraulic point pressures between them. Pressure values can be checked via the vehicle's pressure gauges.



ATTENTION

Lift/lower the vehicle point-by-point, making small height changes for each hydraulic point until the desired height is reached.



WARNING

The vehicle should be used in emergency conditions only for the time strictly necessary and under the full responsibility of the operator, given that the command and control functions of the vehicle are limited and not safely monitored.



WARNING

Operate the controls very gradually and with extreme caution. The absence of an electronic control does not impose any restrictions on the use of the components, which can be overloaded and damaged, with potential risks for transport and persons and property surrounding the vehicle.



WARNING

Constantly check the pressure values of the hydraulic points; avoid exceeding 290 bar with the vehicle loaded (see the diagram in paragraph 10.6.2). During operation, these pressures can oscillate due to roughness of the ground.



WARNING

After completing the manoeuvres, for safety reasons it is advisable to set the vehicle in full low position.

10.8.1 Electric system fault

Preliminary information

When the electronic system does not get activated (failure of the X90 control unit), to lift or lower the vehicle, apply the procedure shown in the following page.

Operating instructions

- 1) Start the engine in emergency conditions (see chapter 8). 
- 2) Push and always hold the joystick (10) all forward to set the engine at maximum speed.

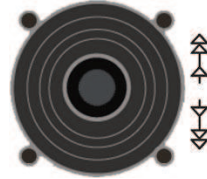

- 3) Close tap [J].

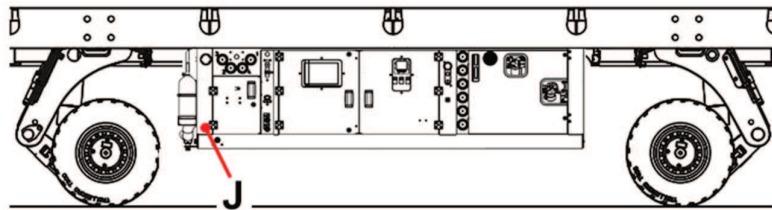

- 4) Release the parking brake: turn the brake adjustment potentiometer (19) of the transmitter on about 0% or a little over (when the potentiometer indicating notch is below 0% the parking brake is engaged).



- 5) Press and hold the enabling button  located over the distributors, in the middle of the pressure gauges, and simultaneously operate the distributors [1], [2], [3], [4] (one distributor at a time).
Pull the lever to lift the corresponding point, push it to lower the point.

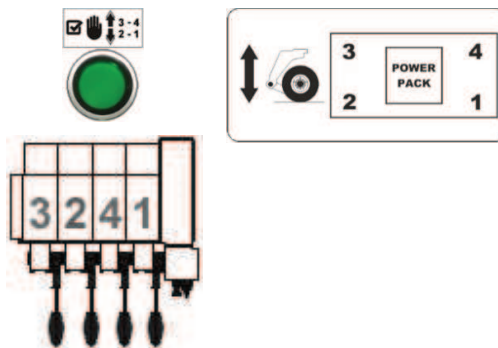

Continued →

Continued "Electric system fault" →

Operating instructions



NOTE
The total lifting/lowering function cannot be performed via the distributor block.

Vehicle lifting/lowering is interrupted when:

- The enabling button is released.
- The lever is released.
- The lifting or lowering limit switch is reached;

10.8.2 Failure of the electrical system / Diesel engine / lifting and steering pump

Preliminary information

In the event of malfunctions or serious faults involving the electrical system or the motor or the lifting and steering pump, which prevent the machine's devices from being switched on and working properly, proceed as follows to raise or lower the vehicle. First of all, it will be necessary to unlock the electro-valves of the lifting distributor block, which are blocked in absence of electrical power.

A) Power pack hand pump procedure

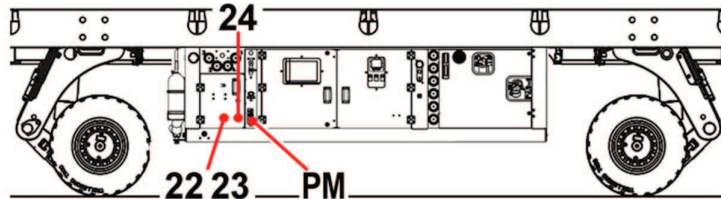

- 1) Operate on the unlock device(s), highlighted in the figure below, of the lifting distributor block electro-valves: turn by hand the wing nut screw into the threaded hole of each device as far as it goes to unlock the valves.

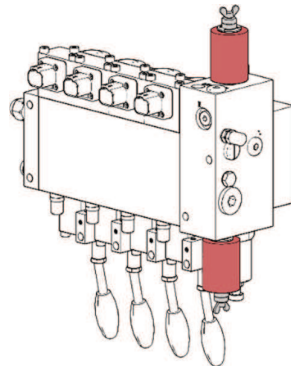

INDICATIVE FIGURE

- 2) Release the vehicle parking brake:
 - a. Close taps [22] and [23].

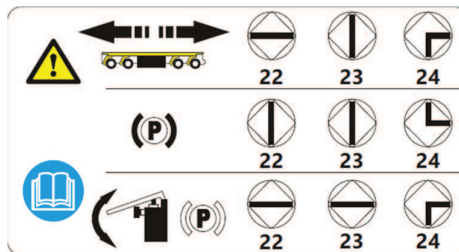

Continued →

Continued →

A) Power pack hand pump procedure

- b. Close the hand pump (PM) handwheel.
- c. Set tap [24] as shown in the plate (lever down).
- d. Pump using the hand pump (PM): the hydraulic oil reaches the hydraulic brake circuit. The brakes are released when the pressure raises to about 200 bar. Check the pressure level on the pressure gauge [M].

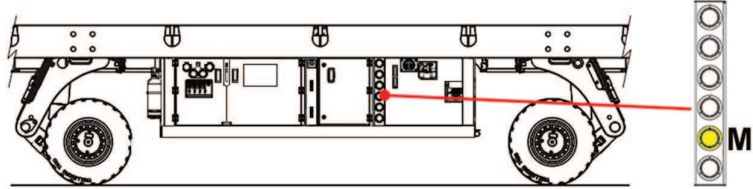

- 3) Set tap [24] as shown in the plate (lever up).

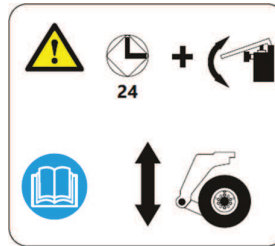

- 4) If necessary, have a second person work on the hand pump lever or on the spool valve block lever, then:
 - To lift a point, carefully pull the relevant distributor block lever and pump. The upward movement only begins when a pressure greater than that indicated by the relevant pressure gauge above the distributor block is reached (see figure below).
 - To lower a point, carefully push the relevant distributor block lever and pump to start the downward movement.
- 5) Proceed point by point, trying to balance the pressure values of the various hydraulic points and keep the loading platform horizontal. Make small height variations (in the order of a few centimetres) for each point, adjusting the ascent or descent with the lever and checking the pressures of the hydraulic points on the gauges [1] - [2] - [3] - [4].

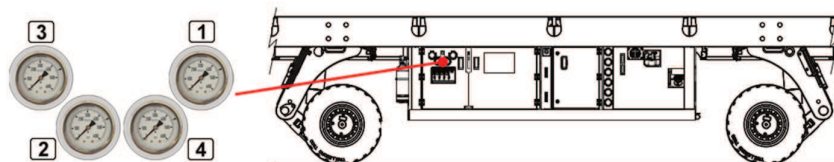

- 6) Continue until the desired height is reached.

**NOTE**

The total lifting/lowering function cannot be performed via the distributor block.

Vehicle lifting/lowering is interrupted when:

- The lever is released.
- The lifting or lowering limit switch is reached.
- Pumping stops.

Continued →

Continued "Failure of the electrical system / Diesel engine / lifting and steering pump" →

B) External auxiliary pump procedure

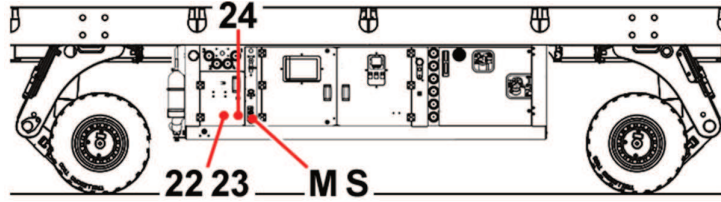

- 1) Operate on the unlock device(s), highlighted in the figure below, of the lifting distributor block electro-valves: turn by hand the wing nut screw into the threaded hole of each device as far as it goes to unlock the valves.

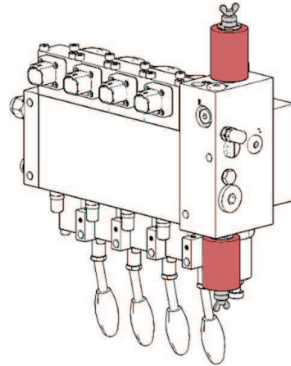

INDICATIVE FIGURE

- 2) Connect the auxiliary pump to the couplings [M] and [S]: the outlet to [M], the inlet to [S].
- 3) Release the vehicle parking brake:
 - a. Close taps [22] and [23].

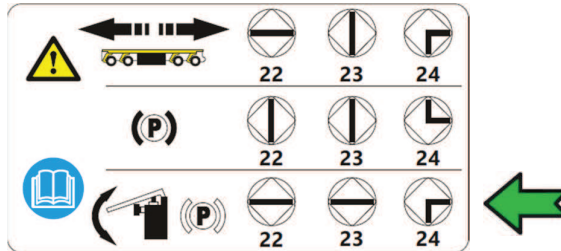

- b. Set tap [24] as shown in the plate (lever down).
 - c. Start or operate the external auxiliary pump: the hydraulic oil reaches the hydraulic brake circuit. The brakes are released when the pressure raises to about 200 bar. Check the pressure level on the pressure gauge [M] or on the pressure gauge of the external auxiliary pump.

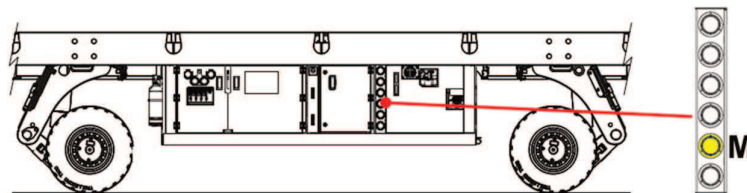

Continued →

Continued →

- B) External auxiliary pump procedure**
- 4) Set tap [24] as shown in the plate (lever up).

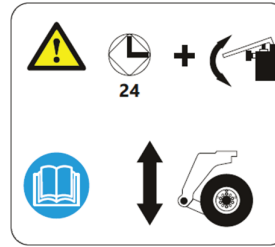

- 5) While the external auxiliary pump is running, operate the distributor block levers as follows:
- To lift a point, carefully pull the relevant distributor block lever. The upward movement only begins when a pressure greater than that indicated by the relevant pressure gauge above the distributor block is reached (see figure below).
 - To lower a point, carefully push the relevant distributor block lever to start the downward movement.
- 6) Proceed point by point, trying to balance the pressure values of the various hydraulic points and keep the loading platform horizontal. Make small height variations (in the order of a few centimetres) for each point, adjusting the ascent or descent with the lever and checking the pressures of the hydraulic points on the gauges [1] - [2] - [3] - [4].

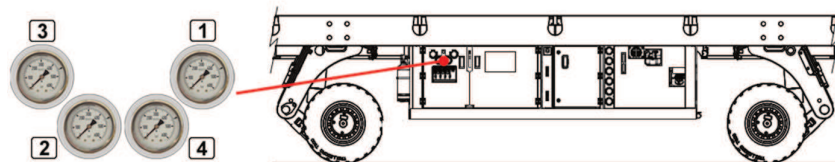

- 7) Continue until the desired height is reached.

**NOTE**

The total lifting/lowering function cannot be performed via the distributor block.

Vehicle lifting/lowering is interrupted when:

- The lever is released.
- The lifting or lowering limit switch is reached.
- The external auxiliary pump is deactivated / is no longer operated.

10.9. REPLACEMENT AND ELECTRICAL CALIBRATION OF A LIFTING POTENTIOMETER

Preliminary information

Each of the suspensions located at the end of the vehicle (suspensions [1] – [2] – [3] – [4]) is equipped with a redundant lifting/lowering potentiometer.

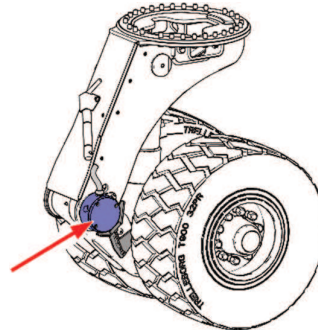



Replace or recalibrate the potentiometer if:

- The vehicle height displayed on the [EB1] electric cabinet and on the radio control does not match the actual height of the vehicle.
- The “potentiometer error” icon shown below is displayed on the [EB1] electric cabinet (main page) and on the radio control (machine status icons page).



To facilitate the operations, perform the procedure described herein, as far as possible, on level ground.

Operating procedure

- 1) Start the Diesel engine (see chapter 8). 
- 2) Set the vehicle to operating height (1500 mm).
- 3) Switch off the Diesel engine and the control board: general key  in position “0”.

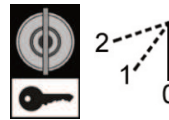

- 4) Remove the protective casing (A).

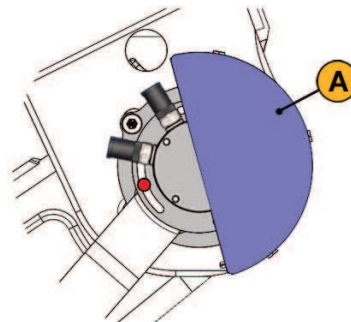

INDICATIVE FIGURE

Continued →

Continued →

Operating procedure

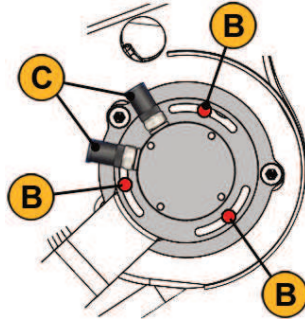

- 5) Disconnect the electrical connectors (C) and remove the lifting potentiometer to be replaced.
- 6) Install the new potentiometer without locking the fixing screws (B).

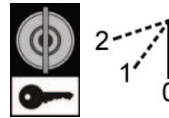

INDICATIVE FIGURE

- 7) Connect the electrical connectors (C) to the new potentiometer.
- 8) Power the vehicle: general key  in position "1".



- 9) The  button (INIT) starts flashing and the buzzer emits a warning sound/light indicating that the system is operational. Once the system is operational, press the  button (INIT); the button light is steadily lit.



- 10) Start the diesel engine (see chapter 8). 
- 11) Open the "Height reset" page of the electronic program. From the main page of the [EB1] electric cabinet display, use the following procedure:
F2 → Password → Enter → Login → Date&time → F4 → F3 → F2.



	1	2	3	4	5	S1	S2	S3	
POINT	Current Value	Low Tmp Value	High Tmp Value	Low Stored Value	High Stored Value	K Value Calculated	SET LOW	SET HIGH	SAVE
1	0	<input type="checkbox"/>	<input type="checkbox"/>	0	0	0.00000	Set L	Set H	SAVE
2	0	<input type="checkbox"/>	<input type="checkbox"/>	0	0	0.00000			
3	0	<input type="checkbox"/>	<input type="checkbox"/>	0	0	0.00000			
4	0	<input type="checkbox"/>	<input type="checkbox"/>	0	0	0.00000			
1r	0	<input type="checkbox"/>	<input type="checkbox"/>	0	0	0.00000			
2r	0	<input type="checkbox"/>	<input type="checkbox"/>	0	0	0.00000			
3r	0	<input type="checkbox"/>	<input type="checkbox"/>	0	0	0.00000			
4r	0	<input type="checkbox"/>	<input type="checkbox"/>	0	0	0.00000			

Continued →

Continued "Replacement and electrical calibration of a lifting potentiometer" →

Operating procedure

- 12) Use the **F1** and **F2** keys to select on the screen the suspension corresponding to the potentiometer to be calibrated.
The potentiometers are redundant: the letter "r" identifies the redundant component. ridondante.



NOTE

Calibrate the redundant part too.

Check that the value in column (1) "Current value" is about **8500**. If not, turn the potentiometer one way or the other until the field more or less displays the above mentioned value: this will prevent the potentiometer going out of range during operation.

- 13) Secure the potentiometer to the suspension: tighten now the screws (**B**).
- 14) Set the vehicle to the full-low position (loading platform height from the ground = 1200 mm).
- 15) If, for the selected suspension, the value displayed in column (1) "Current Value" differs from that in column (4) "Low Stored Value":
- Click on the "Set L" button in column (**S1**) (or press **F3**).
 - The value in column (1) will now appear in column (2) "Low Temporary Value".
 - To confirm the full-low position calibration, press "SAVE" in column (**S3**): the value in column (2) – "Low Temporary Value" will now appear in column (4) "Low Stored Value".
- 16) Set the vehicle to the full-up position (loading platform height from the ground = 1900 mm).
- 17) If, for the selected suspension, the value displayed in column (1) "Current Value" differs from that in column (5) "High Stored Value":
- Click on the "Set H" button in column (**S2**) (or press **F4**).
 - The value in column (1) will now appear in column (3) "High Temporary Value".
 - To confirm the full-up position calibration, press "SAVE" in column (**S3**): the value in column (3) – "High Temporary Value" will now appear in column (5) "High Stored Value".
- 18) In order to save the full calibration of the potentiometer, click on **F5** button.
The program exits the "Height reset" screen to confirm operation success.



ATTENTION

In case of failure to save the new calibration, the program will restore the values stored prior to new potentiometer calibration.

- 19) Click on the date/time pane at the bottom right corner of the screen or rotate the logo knob on keyboard **F_** until the electronic program's home screen is displayed.
- 20) After approx. 5 seconds, switch off the control board → General key  in position "0".